



PCD 818: 2026  
ICS 47.080

## DRAFT ZANZIBAR NATIONAL STANDARD

Small craft — Hull construction and scantlings — Part 6:  
Structural arrangements and details

DRAFT STANDARD FOR PUBLIC COMMENTS

ZANZIBAR BUREAU OF STANDARDS

## National Foreword

This Zanzibar National standard was prepared by the Mechanical and Automotive Standards Technical Committee and approved by ZBS Board of Directors in accordance with the General procedures and guidelines for the development of Zanzibar National Standards.

The Zanzibar Bureau of Standards (ZBS) was established under the Standard Act No. 1 of 2011.

In the preparation of this Standard, the reference was made to the following source:

ISO 12215-6:2008: *Small craft — Hull construction and scantlings — Part 6: Structural arrangements and details*

### Technical Committee Representatives

This Zanzibar National Standard was prepared by the Mechanical and Automotive Standards Technical committee which consist of representatives from the following organizations:

Buda Auto Parts  
Department of Environment Zanzibar (DoE)  
Government Agency for Automobile Workshop Services (GAAWS)  
Karume Institute of Science and Technology (KIST)  
Zanzibar Road Transport and Safety Authority (ZARTSA)  
Zanzibar Electricity Corporation (ZECO)  
Zanzibar Utilities Regulatory Authority (ZURA),  
Zanzibar Bureau of Standards (ZBS) - Secretariat

Zanzibar Bureau of Standards (ZBS)  
PO Box 1136  
Zanzibar  
Tel: +255 24 2232225  
Fax: +255 24 2232225  
E-mail: [info@zbs.go.tz](mailto:info@zbs.go.tz)  
Web: [www.zbs.go.tz](http://www.zbs.go.tz)

# Small craft — Hull construction and scantlings — Part 6: Structural arrangements and details

## 1. Scope

This Standard concerns structural details and structural components and applies to monohull and multihull small craft constructed from fibre reinforced plastics (FRP), aluminium or steel alloys, wood or other suitable boat building material, with a hull length of up to 24 m.

This Standard fulfils two functions. Firstly, it provides further explanations and calculation procedures and formulae. Secondly, it gives a number of examples of arrangements and structural details which illustrate principles of good practice. These principles provide a standard against which alternative arrangements and structural details can be benchmarked.

## 2. Normative references

The following referenced documents are indispensable for the application of this document. For dated references, only the edition cited applies. For undated references, the latest edition of the referenced document (including any amendments) applies.

ISO 8666, Small craft — Principal data

ISO 12215-5:2008, Small craft — Hull construction and scantlings — Part 5: Design pressures for monohulls, design stresses, scantlings determination

ISO 12215-7, Small craft — Hull construction and scantlings — Part 7: Scantling determination of multihulls

ISO 12215-8, Small craft — Hull construction and scantlings — Part 8: Rudders

ISO 12215-9, Small craft — Hull construction and scantlings — Part 9: Appendages and rig attachment

ISO 12216, Small craft — Windows, portlights, hatches, deadlights and doors — Strength and watertightness requirements

## 3. Terms and definitions

For the purposes of this document, the following terms and definitions apply

### 3.1

#### **loaded displacement mass**

<sup>m</sup>LDC mass of the craft, including all appendages, when in the fully-loaded ready-for-use condition, as defined in ISO 8666

### 3.2

#### **sailing craft**

craft for which the primary means of propulsion is by wind power, and for which  $AS > 0.07({}^m\text{LDC})^{2/3}$  where;

$A_S$  is the total profile area of all sails that can be set at one time when sailing closed hauled, as defined in ISO 8666, expressed in  $\text{m}^2$ ;

<sup>m</sup>LDC is the loaded displacement, as defined in ISO 8666, expressed in kg.

NOTE: Non-sailing craft are referred to as motor craft.

### 3.3

#### **grid grillage**

set of transverse stiffeners that intersect a set of longitudinal stiffeners.

### 3.4

#### **secondary stiffener**

stiffening element that directly supports the plating

**NOTE:** In a stiffener grillage, secondary stiffeners usually correspond to stiffeners having the lower second moment of area, e.g. stringers, frames, partial bulkheads. The spacing of secondary stiffeners generally corresponds to the shortest unsupported span of the attached plating. In the case of stiffeners with a substantial base width (i.e. top hat stiffeners), the stiffener spacing will be the unsupported panel span plus this base width.

### 3.5

#### **primary stiffener**

stiffening element that supports the secondary stiffening element

NOTE 1: In a stiffener grillage, primary stiffeners usually correspond to stiffeners which have the higher second moment of area, e.g. structural bulkheads, girders, web frames. The spacing of primary stiffeners generally corresponds to the span of secondary stiffeners.

NOTE 2 Some stiffeners, such as bulkheads, deep girders or web frames, may also contribute to resisting global loads.

### 3.6

#### **Stringer**

longitudinal stiffener, generally designated a secondary stiffener (3.4), which supports the shell plating

### 3.7

#### **frame**

transverse stiffener, generally designated a secondary stiffener (3.4), which supports the shell plating

### 3.8

#### **beam**

transverse stiffener, generally designated a secondary stiffener (3.4), which supports the deck plating

### **3.9**

#### **web frame**

substantial transverse stiffener, generally designated a primary stiffener (3.5), which supports stringers and less substantial girders and is usually connected with substantial deck beams

NOTE: The spacing of web frames is usually greater than (or some multiple of) the frame or beam spacing

### **3.10**

#### **floor**

substantial transverse bottom stiffener, which may be used to link frames and may also be a partial bulkhead NOTE Floors are often used to support a cabin sole, so the upper edge is generally horizontal. On sailing craft, floors are traditionally used to support ballast keels.

## **4. Symbols**

Unless specifically otherwise defined, the symbols and units used in this part of ISO 12215 are given in Table 1.

NOTE: Symbols and units used only in the annexes are not included in Table 1

DRAFT STANDARD FOR PUBLIC COMMENTS

**Table 1: Symbols**

Symbols	Designation	Unit
$A_D$	Design area of plating/stiffener	mm <sup>2</sup>
$b$	Spacing between stiffeners	mm
$bw$	Width of bonding flange	mm
$B_H$	Beam of hull, in accordance with ISO 8666	m
$D_{max}$	Maximum depth of the boat, in accordance with ISO 8666	m
$E$	Elastic modulus of stiffener	N/mm <sup>2</sup>
$f_1$	Mechanical property coefficient for FRP and aluminium alloys	1
$f_{1w}$	Mechanical property coefficient for wood	1
$I$	Second moment of stiffener	Mm <sup>4</sup>
$k_0, \dots, k_2$	Coefficients for reinforcing thickness calculation	1
$k_j, k_{jmin}$	Glue width coefficient	1
$l_u$	Span of stiffeners	mm
$L_H$	Length of hull, in accordance with ISO 8666	m
$L_{WL}$	Length of waterline, in accordance with ISO 8666	m
${}^mLDC$	Loaded displacement mass, in accordance with ISO 8666	kg
$m_T$	Trailing mass, in accordance with ISO 8666	kg
$P$	Maximum engine power	kW
$t_b$	Bottom plating thickness	mm
$t_{BHD}$	Thickness of plywood bulkhead	mm
$t_w$	Total thickness of top hat web	mm
$V_{max}$	Boat maximum speed in calm water	knot
$\sigma_d$	Design direct stress	N/mm <sup>2</sup>
$\sigma_u$	Ultimate direct strength	N/mm <sup>2</sup>
$\tau_d$	Design shear stress	N/mm <sup>2</sup>
$\tau_u$	Ultimate shear strength	N/mm <sup>2</sup>
$\psi$	Glass content by mass	1

## 5. General

Where the load and scantling determination have been accomplished for craft with a hull length,  $L_H$ , of between 2.5 m and 24 m in accordance with

- a. ISO 12215-5 for design pressure for monohulls and scantlings determination,
- b. ISO 12215-7 for multihulls,
- c. ISO 12215-8 for rudders, and
- d. ISO 12215-9 for appendages and rig attachment,

structural arrangements and details shall comply with Clauses 6 to 11.

Where one of the two following methods prescribed in ISO 12215-5 have been used, the craft need only comply with the requirements of Annex A:

- a) for sailing craft with a length,  $L_H$ , of between 2,5 m and 9 m of design categories C and D, where ISO 12215-5:2008, Annex A, has been used;
- b) for craft with a length,  $L_H$ , of between 2,5 m and 6 m and of single skin FRP bottom construction, where ISO 12215-5:2008, Annex B, has been used.

## 6. Structural arrangement

### 6.1 Stiffening

#### 6.1.1 General

The hull, deck and deckhouse plating shall be stiffened as necessary to comply with ISO 12215-5, by any combination of longitudinal and transverse conventional stiffeners, structural bulkheads, internal furniture such as berths and shelves, and internal tray mouldings, providing these may be considered as "load bearing". The arrangement is usually made with stiffeners supported by deeper and stronger stiffeners, crossing perpendicularly.

NOTE: For small boats, "natural stiffeners" (i.e. elements that add stiffness, even if not dedicated for the purpose; see ISO 12215-5:2008, 9.14), e.g. deck edge, round bilges, hard chines, keel, can define panels that need no further stiffening.

Figures 1, 2 and 3 illustrate characteristic arrangements that comply with good practice. These figures apply to both sailing and non-sailing craft, and combinations of arrangement within a single craft are acceptable. Small boats (generally those of hull length less than about 9 m in length) employ natural stiffeners such as deck edge, round bilges, hard chines, keel, etc. to define panels and then need no further stiffening. Larger craft generally need to make greater use of the stiffener types described in 3.3 to 3.12.

#### 6.1.2 Equivalence criteria

Other arrangements are possible, but these shall follow good practice principles (as illustrated by Figures 1, 2 and 3) of effective and smooth transmission of stresses due to pressure loads and concentrated loads (mast, keel, rudder, etc) from the load point into the supporting structure (see 6.3 and 6.4).

#### 6.1.3 Longitudinally framed boat

In the example in Figure 1, the hull shell is stiffened by longitudinal secondary stiffeners supported by transverse primary stiffeners, such as web frames, bulkheads and deep floors. The example given is typical for an FRP boat.

#### 6.1.4 Transversally framed boat

In the example in Figure 2, the hull shell is stiffened by transverse frames (secondary stiffeners) that are typically supported at the centreline, at the chines or turn of bilge and at

deck level. In larger boats, girders (primary stiffeners) may be fitted, which support these frames and also assist in carrying hull girder loads.

### 6.1.5 Small, slow boat stiffened by keel, gunwale stringer, structural sole and thwarts

It is common for small craft (i.e. those of hull length less than 6 m) to have no specific stiffeners. However, components not primarily intended to be stiffeners, such as internal partitions may act as such. These components may need to be reinforced for this other role as “stiffeners”. In Figure 3, the thwarts, front and aft locker, cockpit sole and gunwale are used in this way.

### 6.1.6 Load bearing elements

To be considered as “load bearing”, the supporting member shall be effectively attached to the plating by any combination of welding (continuous or intermittent), bonding with structural quality adhesive (e.g. use of epoxy fillets) or fibre reinforced bonding angles or other methods appropriate to the materials. In addition, the member in question shall be constructed of material acceptable for hull construction in accordance with ISO 12215-5, and shall be able to carry the forces and moments associated with the effective support assumption as defined there.

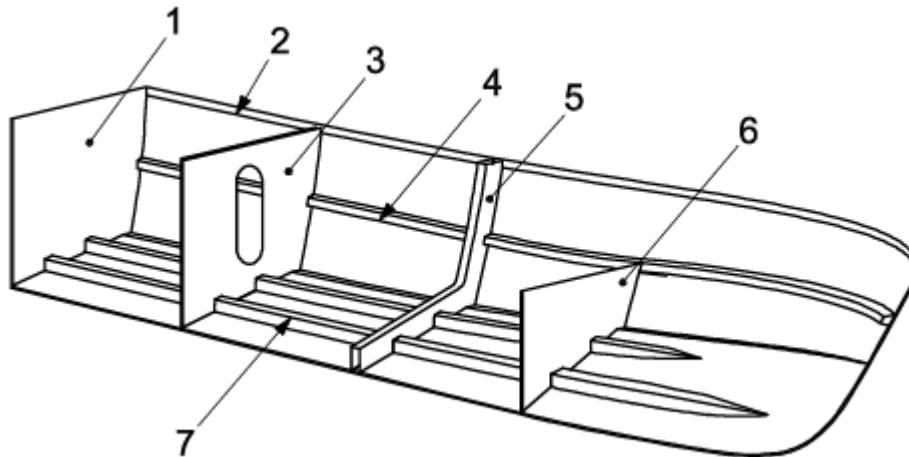

#### Key

1. transom
2. gunwale stringer
3. bulkhead
4. side longitudinal stiffener (stringer)
5. web frame
6. deep floor
7. bottom longitudinal stiffener (girder or stringer); good practice is to have ends in accordance with Figure 4 a) or 4 c)

NOTE 1, 3, 5 and 6 are primary stiffeners; 2, 4 and 7 are secondary stiffeners.

Figure 1: Longitudinally framed boat

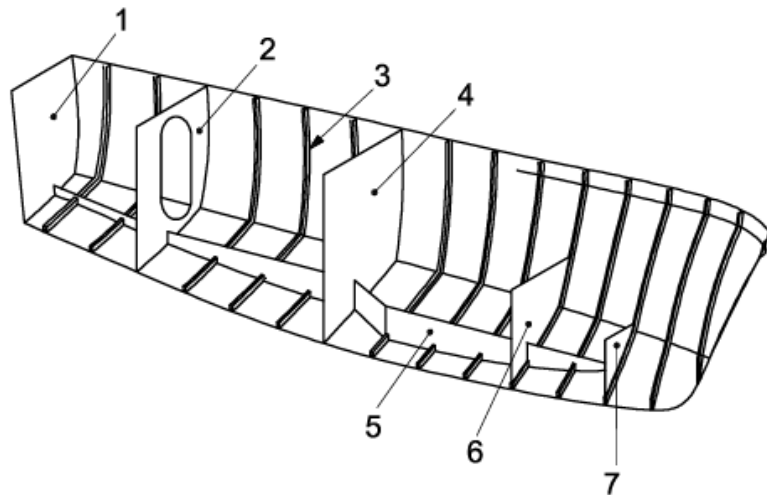

Key

- 1. transom
- 2. bulkhead
- 3. frame
- 4. bulkhead
- 5. bottom girder
- 6. deep floor
- 7. deep floor

Figure 2: Transversally framed boat

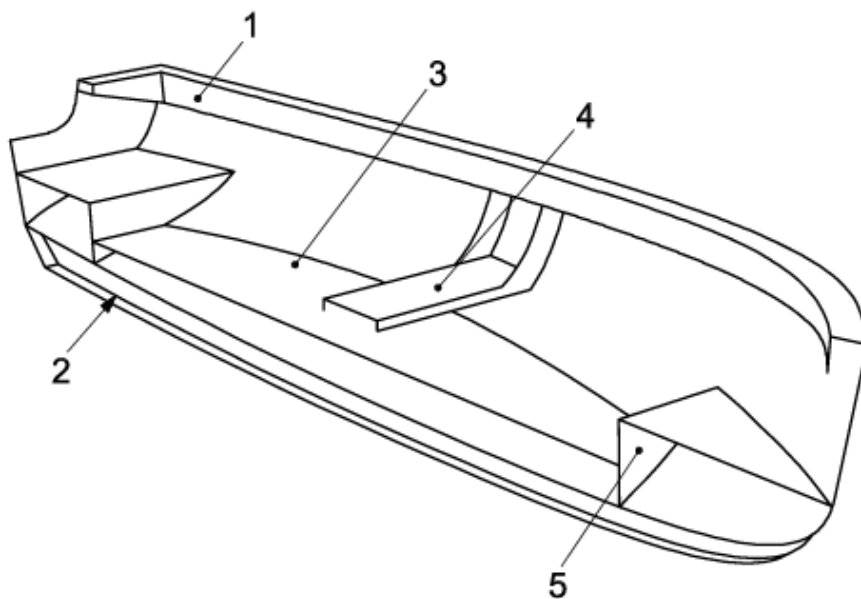

Key

- 1. gunwale stringer
- 2. keel
- 3. structural sole
- 4. thwarts
- 5. deep floor

Figure 3: Small, slow boat stiffened by keel, gunwale stringer, structural sole and thwarts

## 6.2 Hull girder strength

ISO 12215-5 is based on the assumption that hull and deck scantlings are governed by local loads, which is usually the case for craft of normal proportions and is especially so for longitudinally framed craft.

For the following craft, an explicit longitudinal strength and buckling assessment is recommended:

- transversely framed motor craft where max

$$\frac{V_{\max}}{\sqrt{L_{WL}}} > 6;$$

- transversely framed sailboats experiencing large rig loads;
- craft with large deck openings or craft with

$$\frac{L_H}{D_{\max}} > 12.$$

Annex D gives recommendations for the assessments to be made.

## 6.3 Load transfer

### 6.3.1 General

The structural geometry shall be so arranged and detailed as to ensure a smooth transfer of loads throughout the structure. Concentrated loads (e.g. mast step for a keel stepped mast, mast pillar for a deck stepped mast) shall be transmitted into the surrounding structure by a series of stiff supporting members. In no case shall concentrated load points be landed on unsupported plating. In general, concentrated loads shall be introduced into the adjacent structural elements by shear load carrying brackets, flanges or floors. Knife edge load crossing shall be avoided (see 6.3.5).

6.3.2 gives examples of good practice load transfer arrangements. Other arrangements need to be specifically engineered.

### 6.3.2 Examples of good practice load transfer arrangements

The list below gives examples of good practice load transfer arrangements.

Stiffeners (generally angle bar, tee section, top hats or flat bars, etc.) and girders (including engine girders) do not terminate abruptly, but are suitably terminated to develop their bending strength and shear strength at the supporting member, with brackets or without brackets, but with structurally effective attachment of web and flange to the supporting member (see Figure 4). Where stiffeners are lightly loaded, they may have tapered (sniped) ends, provided the slope of the taper is at least 30 % and that the plating between the end of the stiffener and the supporting structure is designed or able to transmit the shear force and bending moment of the tapered stiffener [see Figure 4 c)].

Floors smoothly taper in depth towards that of the attached transverse frame. Where no transverse frames are fitted, the floor is attached to the side shell over a sufficient length to ensure that the shear force (due to keel moment or bottom pressure) can be adequately transferred to the side shell (see Figure 5). The ends of floors or transverse stiffeners for sailboat ballast keel are in accordance with the requirements of ISO 12215-9.

Cut-outs and sharp corners are avoided in load-carrying structures such as shell, deck, primary and secondary stiffening members. Where cut-outs cannot be avoided, the depth of any cut-out does not exceed 50 % of the depth of the web of the member, and the length of the cut-out does not exceed 75 % of the depth of the web of the member, unless

effectively engineered. Cut-outs shall have radius corners not less than 12 % of the cut-out depth or 30 mm, whichever is the greater. Cut-outs are avoided within 20 % of the span from the support points and by way of concentrated loads on the member.

### 6.3.3 Openings in deck and shell according to good practice

Openings in decks and shell have radius corners not less than 12 % of the width of opening, but need not exceed 300 mm and are not less than 50 mm. This does not apply where the edges are reinforced by a structural flat bar or equivalent (see Figure 6).

It is also good practice to minimize sharp cut-outs in structurally loaded panels and stiffeners, unless accordingly reinforced.

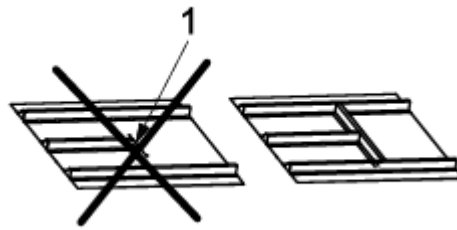

a) Stiffener ending in panel, poor practice and good practice solution

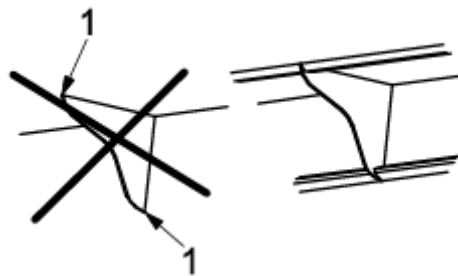

a) Bracket, poor practice and good practice solution

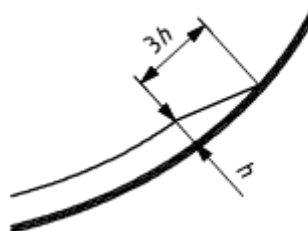

c) Tapered ends acceptable provided the vertical load can be taken by the shell

Key

1- risk of crack

$h$  - height of stiffener

Figure 4: Detail of stringer and bracket end

DRAFT STANDARD FOR PUBLIC COMMENTS

### 6.3.4 Floating frame systems

Floating frame systems (see Figure 7) are those where one set of stiffeners (the “floated” stiffeners) effectively sits on top of another set without being directly attached to the hull plating. Only the second set (the “attached” stiffener) is directly attached to the plating. When analysing such floating frames using ISO 12215-5, the effective plating of the floating frame is to be taken as zero.

For all materials, particular metal boats or wooden boats that use plywood frames, these “floating” frames are normally I beams “attached” to a T, L or U stringer. Attention shall be given to the strength of the weld or glued area between the “floating” frame and stringer, torsional (tripping) or shear buckling of the stringer and the frame transverse web and knife edge load crossing (see 6.3.5), which requires explicit calculation. By way of guidance, the weld or glue area shall generally not be less than the stiffener web area,  $AW$ , given by ISO 12215-5:2008, Equation (48).

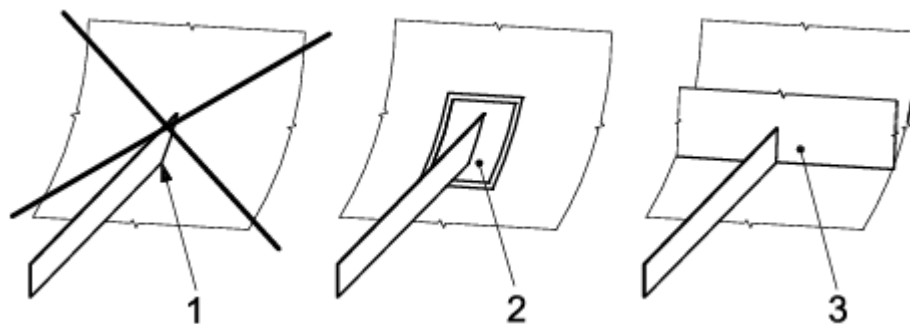

a) Stiffener ending in shell, poor practice and good practice

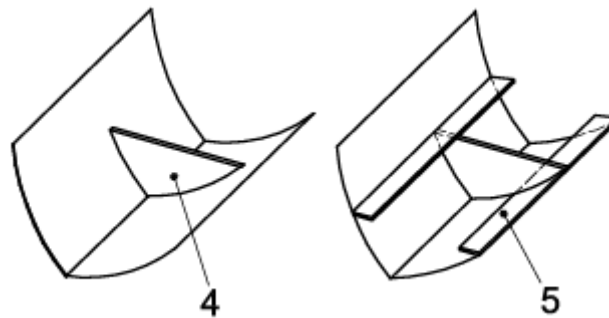

b) Deep floor/partial bulkhead

#### Key

1. hard spot, risk of crack, poor practice
2. reinforced plating, acceptable practice
3. transverse floor or bulkhead, good practice
4. no longitudinal structure at top end of deep floor, acceptable practice
5. cabin sole, deck or longitudinal stiffener on top of floor, good practice

**Figure 5: Detail of stiffener ending on the plating**

Dimensions in millimetres

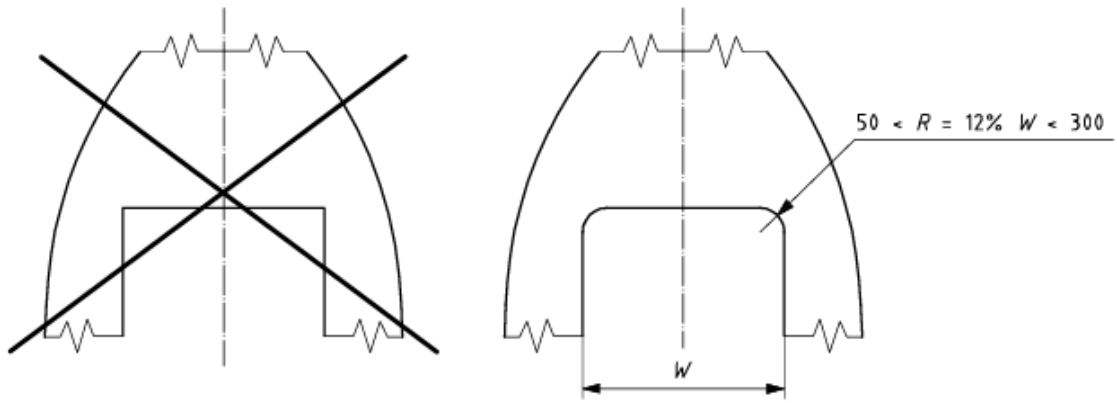

**Key**

R radius corner

W width of opening

Figure 6: Deck and shell openings corner radius

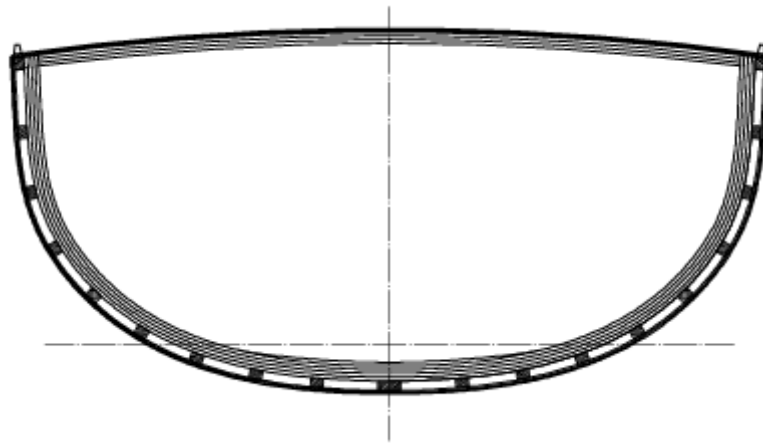
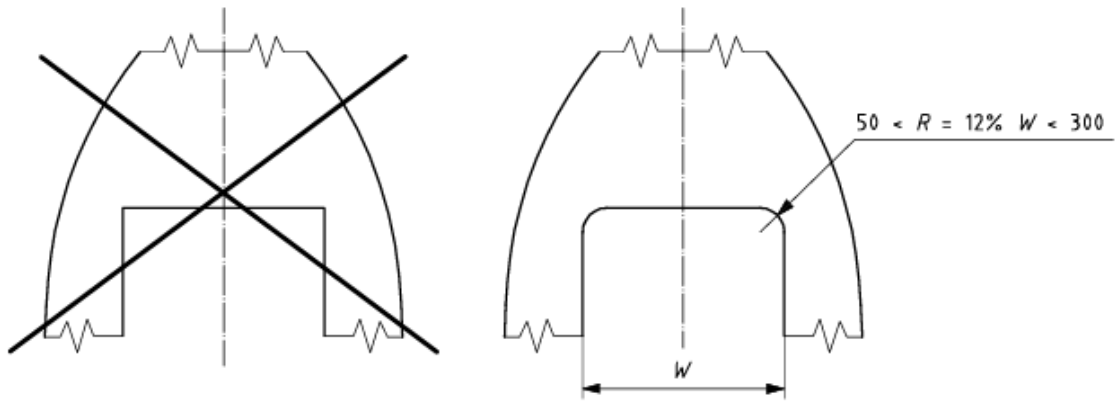

Figure 7: Section of a wooden boat with floating frame

Dimensions in millimetres



**Key**

R radius corner

W width of opening

Figure 6: Deck and shell openings corner radius

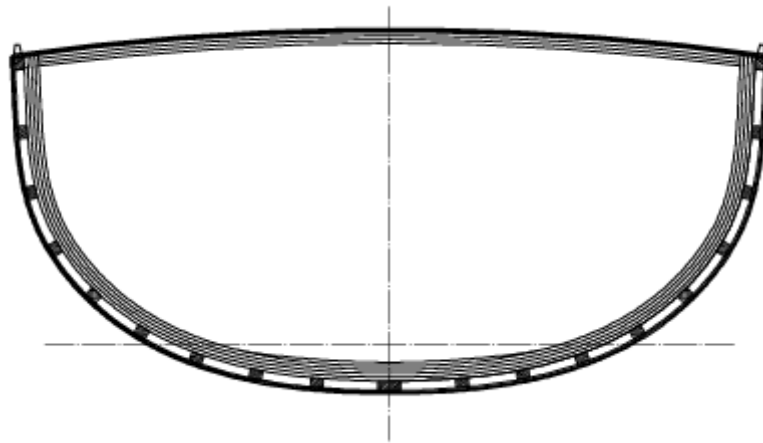

Figure 7: Section of a wooden boat with floating frame

The span of primary members,  $l_u$ , is the grid dimension in the direction of the primary member.

The span of secondary members,  $l_u$ , is the spacing of the primary member.

EXAMPLE Side transverse frames 120 mm deep, spaced 900 mm, run from the deck edge at side to a sharp chine, for a distance of 1 900 mm. Longitudinal side stringers 50 mm deep are spaced at 300 mm between centres.

The transverse frames are the primary members, with a span  $l_u$  of 1 900 mm and a spacing  $b$  of 900 mm. The longitudinal stringers are the secondary members, with a span,  $l_u$  of 900 mm and a spacing  $b$  of 300 mm.

### 6.3.5 Stiffeners crossing similar depth stiffeners

#### 6.3.5.1 General

This arrangement is commonly found in small craft as a tray moulding (see Figure 9) and is often referred to as “egg-box” style. Neither set of members can be categorized as primary or secondary as the degree to which one set supports the other is indeterminate by simple means of assessment.

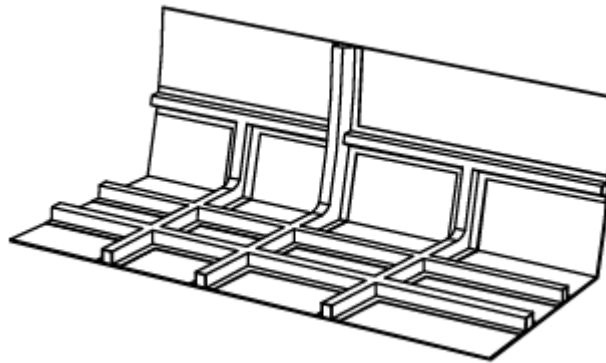

NOTE: The tray moulding shown is pre-moulded with glued flanges, but it may also be laminated in situ.

Figure 9: “Egg-box” style tray mouldings

In such cases, the procedure described in 6.4.3.2 and 6.4.3.3 shall be adopted.

#### 6.3.5.2 Stiffeners running in the shorter of the grid dimensions

The span used to determine the design bending moment and shear force shall be taken as 60 % of the grid dimension. The design pressure shall be obtained using a design area,  $AD$ , based on the stiffener spacing and 60 % of the grid dimension.

#### 6.3.5.3 Stiffeners running in the longer of the grid dimensions

The span to be used to determine the design bending moment and shear force shall be taken as 150 % of the distance between intersection points.

The design pressure shall be obtained using a design area,  $AD$ , based on the stiffener spacing and 150 % of the distance between intersection points.

**EXAMPLE** An egg-box consists of 75 mm deep top hat sections running in both directions. The top hats are spaced 600 mm apart for both sets. The grid is 2 300 mm long × 1 700 mm wide.

For the stiffeners running in the 1 700 mm direction: Spacing = 600 mm, span =  $0,6 \times 1700 = 1\ 020$  mm. Design pressure based on design area of 600 mm × 1 020 mm.

For stiffeners running in the 2 300 mm direction: Spacing = 600 mm, span =  $1,5 \times 600 = 900$  mm. Design pressure based on design area of 600 mm × 900 mm.

#### **6.3.5.4 Cautionary note**

The method described in 6.4.3.2 and 6.4.3.3 is a considerable simplification of the real behaviour of grids. Depth is used as an indicator of flexural stiffness,  $\frac{EI}{l_u^3}$ . The procedure assumes that the dimensions of the grid, and in the case of the method described in 6.4.3.2 and 6.4.3.3, the number of stiffeners and member layups, in the two directions, are broadly similar: this presumption explains why in this case the shorter grid dimension is used, since for similar layups the grid will be stiffer in the short direction and attract greater stress (analogous to plate equations).

#### **6.3.5.5 Example of a grid that may not fit within the governing assumptions**

A grid where the condition specified in 6.4.3.4 would not be satisfied would be one which runs, for example, for 6 000 mm in one direction with just two tophat engine bearers containing carbon fibre in the crowns, with approximately ten CSM/WR tophats running at 90° with a grid dimension of 1 500 mm.

It is not possible to provide simplified assessment methods to cover all structural configurations. The lack of such a simplified method within ISO 12215 should not be interpreted as precluding the use of other arrangements.

### **6.3.6 Shear transmission with regard to “egg-box” style tray mouldings**

#### **6.3.6.1 Good practice example**

The webs of egg-box grids composed of tophat stiffeners are continuous in at least one and preferably both grid directions. Where the grid is pre-moulded leaving a hollow cruciform at the intersection point, a shear web is bonded in place, with recognition given to the generally lower strength of secondary bonded components. Where a secondary bond is used or where the web frame is continuous in one grid direction only, the web shear area as required in ISO 12215-5 is increased by 20 %.

#### **6.3.6.2 Equivalence criteria**

Where a hollow cruciform does exist and there is no continuity of the shear web in the finished state, the arrangement is deemed to be acceptable if – the shear stress immediately adjacent to the hollow cruciform point is less than 20 % of the design shear stress, or – additional reinforcement is provided on the outside of the intersection point and the adequacy of this reinforcement is substantiated by calculation or test.

### **6.4 Window mullions**

A mullion is a stiffener supporting the window (i.e. the vertical frame of the window). Large openings, with or without windows, introduce demands on the mullion structure. The mullions shall be analysed under the two separately occurring load cases outlined below.

**NOTE** It is assumed that the loads are transitory and will not occur simultaneously.

Load case 1: simply supported beams carrying a uniformly distributed load equivalent to the deckhouse side or front load, as defined in ISO 12215-5, according to position. The loaded width is to correspond to the mullion spacing where windows are fitted. The allowable stresses should be those specified in ISO 12215-5.

Load case 2: simply supported compression strut, carrying a load equal to the total pressure load on the deck structure, as defined in ISO 12215-5, supported by the mullions divided by the number of mullions that support this load. The compressive load at failure should be calculated using a Rankine-Gordon or Perry-Robinson style formula, which allows for interaction between columns and strut behaviour. The compressive load shall be at least twice the applied load as calculated above.

With regard to the treatment of windows:

- a) non-bonded windows are considered non-effective;
- b) for bonded windows, the strength of the panels and/or mullion shall be analysed together.

As glazing material used in windows, e.g. PMMA (acrylic) and glass, are more brittle than normal engineering materials, the safety factor shall be greater than that given in ISO 12215-5 and shall be taken from ISO 12216.

## **6.5 Sailboat mast support**

Details relating to sailing boat mast support are given in ISO 12215-9.

## **7. Specific structural details for FRP construction**

### **7.1 Local reinforcement**

#### **7.1.1 General**

Vulnerable areas shall be protected against minor groundings, docking and/or trailering forces and contact with floating objects (e.g. stem, exposed keel or centreline areas, chines). This protection may be provided by local reinforcements, e.g. rubbing stake, bracket, bulkhead), additional lamination, laminate overlap, etc.

7.1.2 shows good practice reinforcement by extra lamination or overlap.

#### **7.1.2 Good practice reinforcement by extra lamination**

##### **7.1.2.1 Protective keel**

A protective keel in this context is a pronounced knuckle or profile normally running at the centreline of the hull comprising the lowest part of the hull. A multihull may have one protective keel in each hull. Even if a ballast keel on a sailboat is strictly a protective keel in this sense, the requirements in ISO 12215-9 shall supersede the contents of this subclause. If the hull bottom is flat or rounded without a pronounced knuckle, the hull has no protective keel in the sense of this subclause.

The features of a protective keel are as described in a) and b) below.

- a) Reinforcement against abrasion and minor grounding: the keel is reinforced to increase impact resistance from minor grounding. This is considered to be fulfilled if there is a reinforced laminate zone, as explained in Figure 10 and Equation (1), within  $(80 \times BH)$  mm from the centreline.

NOTE The result is expressed in millimetres; BH is expressed in metres.

- b) Sufficient strength for docking and/or trailering: the keel is designed to withstand docking and/or the trailering load shall be capable of carrying, without failure, distortion or fracture, the loaded displacement mass of the craft at any point along the keel, unless other guidance on docking is given in the owner's manual. This is considered to be the case if the keel fulfils the following good practice.

The section modulus of the keel around the horizontal axis,  $SM_{EEL}$ , calculated in  $cm^3$ , is at least

$$SM_{KEEL} = 1,4 \times 10^{-3} \times f_1 \times m_T \times L_H$$

where  $m_T$  is the mass in trailering condition in accordance with ISO 8666, in kg, and

$$f_1 = \frac{130}{\sigma_{fu}}$$

where  $\sigma_{fu}$  is the ultimate flexural strength of laminate, in  $N/mm^2$ . (2) In calculating the actual section modulus of the keel, the effective plating (see ISO 12215-5) is 20 times the bottom plating thickness either side of the keel

#### 7.1.2.2 Protective stem

The protective stem is the foremost part of the hull reaching from the waterline in  $m_{LDC}$  conditions up to the deck, or gunwale.

The laminate is in accordance with 7.1.2.4, in areas shown in Figure 10, and within  $(40 \times B_H)$  mm from the centreline.

NOTE: The result is expressed in millimetres;  $B_H$  is expressed in metres.

#### 7.1.2.3 Protective chines

Stresses from global hull bending and torsion tend to concentrate in chines. In addition, chines are vulnerable to abrasion. Therefore, chines with an included angle of at most  $130^\circ$  are reinforced in accordance with Figure 10 and 7.1.2.4, and within  $(40 \times B_H)$  mm from the centreline.

NOTE The result is expressed in millimetres;  $B_H$  is expressed in metres.

#### 7.1.2.4 Reinforcement of protected zones

The minimum mass of fibre reinforcement of protected zones is as specified below.

For the protective keel, stem and chine, the minimum dry glass weight of reinforcement for bottom,  $w_{min}$ , as defined in ISO 12215-5:2008, Equation (47), is:

- $(2.2 \times w_{min}) \text{ kg/m}^2$  for protective keel;
- $(2.0 \times w_{min}) \text{ kg/m}^2$  for protective stem;
- $(1.7 \times w_{min}) \text{ kg/m}^2$  for protective chine.

### 7.1.3 Alternative criteria

The purpose of 7.1.2 is to provide quantitative measures of robustness, which may be either adopted by builders or used for benchmarking purposes. Alternative methods of local reinforcement are acceptable provided a similar level of robustness to that implied by 7.1.2 is demonstrated either by calculation or by test.

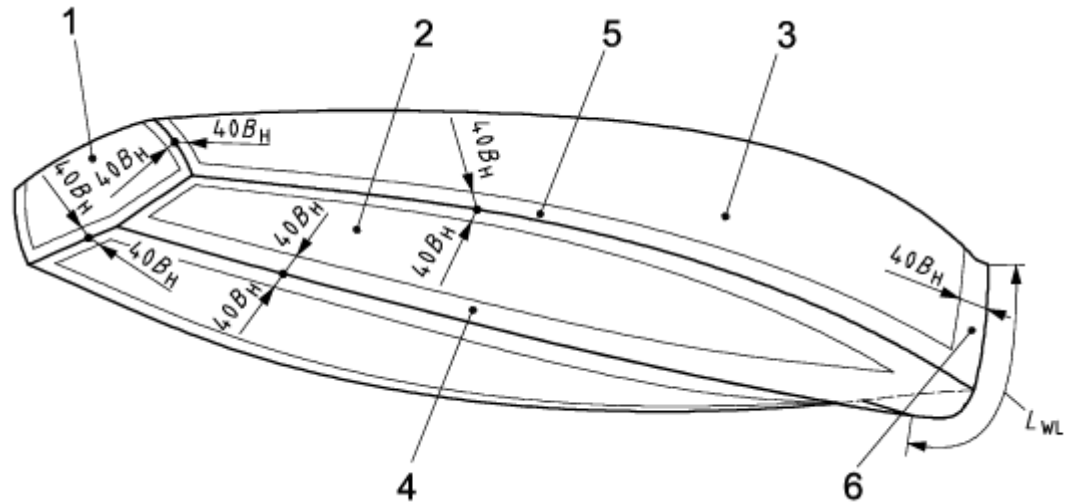

Key

- 1. transom
  - 2. bottom plating
  - 3. side plating
  - 4. protective keel
  - 5. protective stem
  - 6. protective chine
- BH- beam of hull  
LWL- length of waterline

Figure 10: Reinforced areas of the laminate

## 7.2 Bonding

### 7.2.1 General

It shall be noted that the shell or deck thickness requirements of ISO 12215-5 do not include the thickness of the tabbing or bonding flange of the attached stiffener.

**NOTE** The reason for this requirement is that the strength requirements of ISO 12215-5 assume a degree of panel end fixity of between 100 % and 50 %, which means that the panel design bending moment may occur at the centre of the panel and not necessarily at the edge. In addition, there is no benefit from the tabbing between the top hat webs.

The connection between structural elements shall be able to transmit the forces determined in ISO 12215-5, with the same design stresses or less. This connection is generally made by tabbing, glueing, filleting with structural adhesive, mechanical fastening or a combination of these. The method described in Annex B may be used to assess stresses in the glue line.

According to these calculations, it appears that the connection of structural members needs to be considered as a function of the shear stress or shear flow it has to transmit in accordance with the following classification (see also ISO 12215-5:2008, 11.6 and 11.7, and

Tables 20 and 21):

- a) top hats designed to be loaded with stresses close to  $\sigma_d$  and  $\tau_d$ , in accordance with ISO 12215-5, transmit high shear stress and shear flow;
- b) high stiffeners, like bunk sides or deep structural elements, transmit moderate shear stress and shear flow;
- c) very high stiffeners, like bulkheads (where not heavily loaded by mast or rig loads), transmit low or moderate shear stress and shear flow.

The preceding consideration explains why the connection of a stringer or of a ballast keel floor is more critical than that of a bulkhead (see 7.2.4 for bulkhead attachment).

### 7.2.2 Stiffener connection by tabbing

Tabbing is a connection by angles laminated in situ. Where tabbing is made with a material similar to the one of the web, the total thickness of tabbing need not be greater than the total thickness of the web. Where practical, tabbing on both sides is good practice.

#### 7.2.3 FRP top hat typical connection

##### 7.2.3.1 General

Five typical good practice arrangements are given in Figure 11.

Dimensions in millimetres

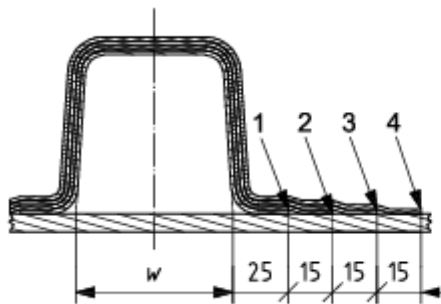

a) Tabbing as in textbooks

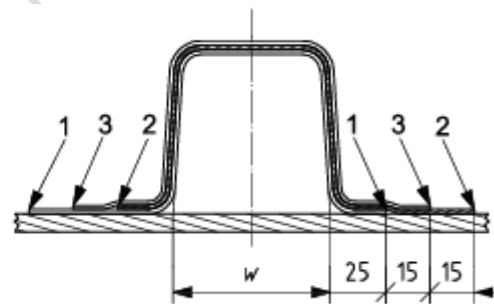

b) Staggered tabbing

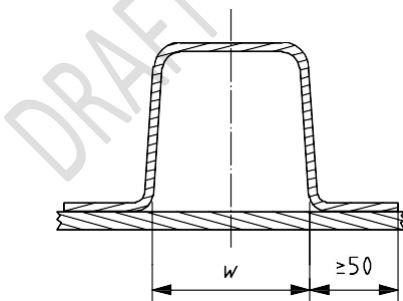

d) Typical boatbuilder's tabbing

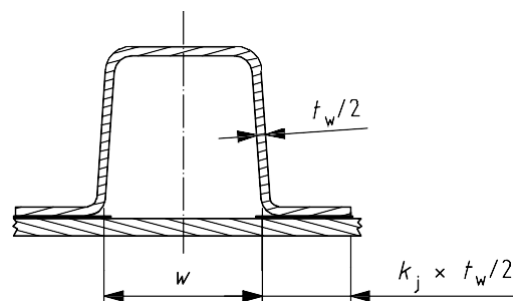

d) Typical glued stiffener

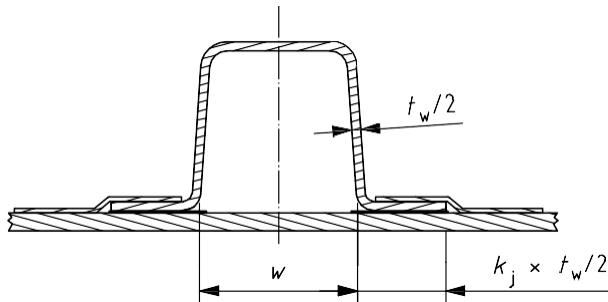

#### e) Glued plus extra tabbing

##### Key

1, 2, 3, 4	ply in order of laminating
$k_j$	glue width coefficient
$t_w$	total thickness of top hat web
$w$	width of opening

Figure 11: Various typical top hat connections

#### 7.2.3.2 Top hat tabbing as in textbooks [(Figure 11 a)]

Figure 11 a) shows a tabbing arrangement for stiffener made by laminating FRP over a form. It is similar to the one recommended by text books or class societies for stringers and transversal frames: the first ply is 25 mm in width; the other plies are minimum 15 mm wide per 0.600 kg/m<sup>2</sup> of glass fibre. Each layer covers the previous and overlaps by the indicated width. For fibres other than glass, the method described in Annex B may be used to calculate the overlap.

This arrangement is designed to ensure that each layer transmits its shear load directly to the plating, not through previous layers.

#### 7.2.3.3 Top hat tabbing in accordance with industry practice [(Figures 11 b) and c)]

Figure 11 b) shows an intermediate tabbing between Figures 11 a) and c): “staggered” tabbing, meaning that all plies have the same width, i.e. former laminate + [(2 × 25) + (2 × 15)] mm. Ply 1 overhangs the former by 25 mm on the left, ply 2 overhangs the former by 25 mm on the right, and ply 3 is centred in the former.

Figure 11 c), with no staggering, is typical of the practice of many boatbuilders. This configuration has proven satisfactory for stringers on craft below 12 m when executed by builders using best practice construction techniques. However, local details such as this one are highly dependent on the skill of the fabricator. Compliance with these typical configurations alone (i.e. without any supporting evidence of good performance) does not guarantee a reliable bond. Responsibility lies entirely with builder and Figure 11 c) is to be regarded as indicative only. Assessment of tabbing or glueing width is discussed in 7.2.3.5.

#### 7.2.3.4 Glued prefabricated top hats, liners or tray mouldings good practice [(Figures 11 d) and e)]

Top hats and liners are frequently prefabricated. The configurations shown in Figure 11 d) correspond to arrangements which have proven satisfactory for stringers on craft below 14 m when executed by builders using best practice construction techniques. Figure 11 e) shows an extra tabbing layer, frequently added in areas with higher stress like ballast floors.

### 7.2.3.5 Width of tabbing or glueing

The purpose of tabbing or glueing is to transmit the shear force from the plating to the web, using interlaminar or glueing shear strength of the connecting flange. ISO 12215-5:2008, Annex H, already discussed this subject to a certain extent

The values given below are highly dependent on the skill of the user, the specific material and the surface preparation and should therefore be taken as guidance only. They shall be validated by test or long term practice. The gap between the stiffener and the shell is also of importance, as stiff elements will not easily fit to the hull surface. In this case, glues with good gap-filling capabilities should be employed

Figures 11 c) to e) show the bonding width of the flange,  $b_w$ . The coefficient  $k_j$  is the ratio between the bonding width and half the web thickness, as calculated in Equation (3):

$$k_j = \frac{b_w}{\left(\frac{t_w}{2}\right)} \quad \dots (3)$$

The ratio calculated in Equation (3) shall be greater than the minimum coefficient value,  $k_{jmin}$ , as calculated in Equation (4):

$$k_{jmin} = \frac{\tau_{dw}}{\tau_{db}} \quad \dots (4)$$

where

$\tau_{dw}$  is the design shear stress of the top hat or liner web given in ISO 12215-5, in N/mm<sup>2</sup>;

$\tau_{db}$  is the design shear stress of the glueing bond (see Clause B.3), in N/mm<sup>2</sup>.

Consequently, the minimum width of the bonding flange,  $b_{wmin}$ , expressed in mm, shall be calculated as in Equation (5), but shall not be less than 50 mm.

$$b_{wmin} = \frac{t_w \times \tau_{dw}}{2 \times \tau_{db}}$$

Where

$\frac{t_w}{2}$  is half the width of the top hat or liner web, in mm.

Table 2 gives good practice values of  $k_{jmin}$  for polyester or epoxy glue or paste. Intermediate values may be obtained by interpolation. More precise or detailed values are provided in Annex B.

**Table 2: Good practice values for  $k_{jmin}$  for glass laminates**

Glass fibre type	Glass content in mass $\Psi$	Polyester or vinylester resin glue or paste	Cold cured epoxy resin glue or paste
Mat/roving/quadraxial	0.35	12	7
Double bias	0.35	20	11

Mat/roving/quadraxial	0.50	14	8
Double bias	0.50	23	13

This glue joint calculation need not be done for every stiffener, but only for a representative sample.

In case of high stress on the web (floors junction), an extra tabbing laminated in situ is added, as shown in Figure 11 e).

If the shear stress in the stiffener web is less or equal to 80 % of the intralaminar design shear stress, then the

$kj$  values may be reduced as follows.  $kj$  is as given in Table 2 or in Clause B.4 multiplied by  $\frac{\tau_{aw}}{\tau_{dw}}$

where  $\tau_{aw}$

and  $\tau_{dw}$  are respectively the design shear stress and actual shear stress in the web. However, the bond width shall not be less than 50 mm.

#### 7.2.4 Other good practice tabbing applications for bulkheads, partial bulkheads bunk sides, etc.

Where the member being connected is single skin, the tabbing thickness need not exceed the thickness,  $t_w$ , of the attached web (see Figure 12) if it is of the same form of reinforcement as the single skin member being attached.

Where the member being connected is a sandwich laminate, the thickness of the tabbing need not exceed the thickness of the sandwich skin being connected, if it is of the same form of reinforcement as the sandwich laminate skin.

Figure 12 shows typical practice employed by many boatbuilders. It can be applied to any type of stiffener, including glued liners or stiffener grids. The configurations shown in Figure 12 correspond to arrangements which have proven satisfactory when executed by builders using good practice construction techniques. However, local details such as this are very dependent on the skill of the fabricator. Compliance with these typical configurations alone (i.e without any supporting evidence of good performance) does not guarantee a reliable bond. Responsibility lies entirely with builder, hence Figure 12 is to be regarded as indicative only.

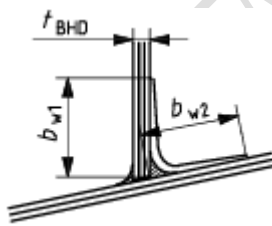

a) Tabbing on both sides only

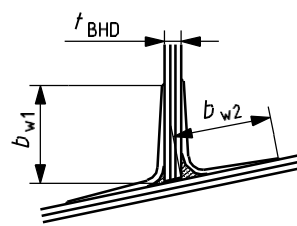

b) Thicker tabbing on one side

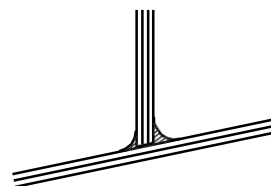
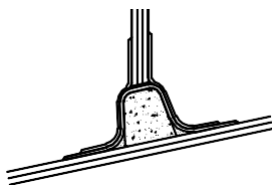

c) Tabbings on a top hat

d) Glueing on both sides

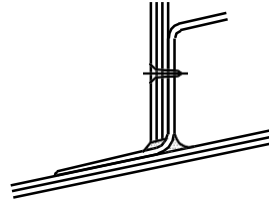
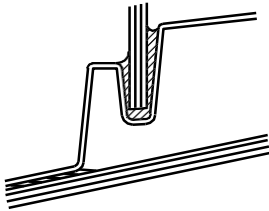

e) Glued in a groove in a liner

f) Mechanical connection plus glue with liner

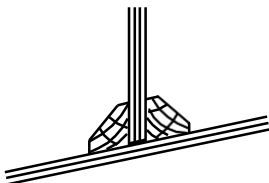

g) Connection via glued wooden cleats

**Key**

$b_{w1}, b_{w2}$  bonding angle tabbing

$t_{bhd}$  thickness of plywood bulkhead

Figure 12: Typical bulkhead connections

**7.2.5 Good practice connection between plywood bulkhead and shell**

Where a plywood bulkhead is connected to the hull and deck, the attachment shall be structurally efficient and, wherever possible, connected on both sides. As with any other kind of tabbing, adhesive selection, faying area preparation and workmanship are critical.

Good practice arrangements which have been found to be satisfactory by builders are as follows:

- a. bonding angle tabbing ( $b_{w1}$  and  $b_{w2}$  in Figure 12) of  $(3 \times t_{BHD})$  mm but no greater than 75 mm;
- b. bonding angle tabbing reinforcement mass of  $(0.06 \times t_{BHD})$  kg/m<sup>2</sup>.

NOTE 1: The figures in a) and b) above are given for guidance and are to be regarded as indicative.

These values apply for tabbing on both sides: if only one side can be tabbed for lack of access, it is a good practice that the laminate mass be raised by 30 % to 50 %.

For plywood sandwich bulkheads,  $t_{BHD}$  is the combined thickness of the skins, presumed to be about equal.

Plywood bulkheads may also be bonded to the hull or tray moulding or liner, provided it is able to transmit, with a large margin of safety, the shear loads determined in ISO 12215-5.

NOTE 2: A large margin means a design stress of 0.25 times the ultimate stress (see Annex B).

## 7.3 Major joints

### 7.3.1 Hull-deck joint

The hull/deck joint shall be designed and built to achieve structural integrity and continuity between hull and deck and, where relevant, to withstand compressive loads from overall bending (sagging). However, it does not need to be stronger than the side shell or deck structure, whichever is the lesser.

The hull/deck joint of fully-decked boats in design categories A, B and C shall be watertight. This also applies to the deck of partly decked boats.

Typical good practice hull-deck joints are (see Figure 13):

- a. connection with a mechanical fastener (bolt, rivet, screw, etc.); in this case, a metal or wood backup inner plate is usually required;
- b. overlapping laminate;
- c. glueing;
- d. a combination of these measures.

Where the sheer or the hull/deck joint is the widest part of the boat, it is good practice to reinforce it to withstand the loads from docking and ashore handling of the craft.

Where the deck is required to be watertight (e.g. for stability), the hull-deck joint shall be watertight.

Where laminates are mechanically connected, the fastenings shall be of a corrosion resistant metal or protected against corrosion. The fasteners shall be spaced and positioned so as not to impair the efficiency of the joint. Washers and nuts shall be of a compatible material. The edges of the laminate and the fastening holes shall be sealed.

Arrangements which have been found to be satisfactory by builders are as follows:

- a) bolt or screw diameter of  $(2.8 + 0.42 L_H)$  mm;
- b) bolt or screw spacing of  $(190 + 4.25 L_H)$  mm;
- c) overlap width of  $(4 \times L_H)$  mm, with a minimum value of 30 mm.

NOTE 1: The values in a), b) and c) above are given for guidance and are to be regarded as indicative [see Figure 13 a)].

NOTE 2: The values in a), b) and c) above are expressed in millimetres;  $L_H$  is expressed in metres.

NOTE 3: The values in a), b) and c) above apply where the strength of the joint is considered to rely only on bolt strength (i.e the eventual paste is considered only for watertightness). If the paste has a significant glueing function, the above values are less valid.

In the case of a hull deck joint made exclusively or mainly with glue, the builder shall base his practice on past experience and/or tests, and shall work in close connection with the glueing compound manufacturer.

Alternative arrangements to those listed above may be used provided they are able to transmit

efficiently the hull/deck connection loads; however, it is recommended to rely on successful past experience.

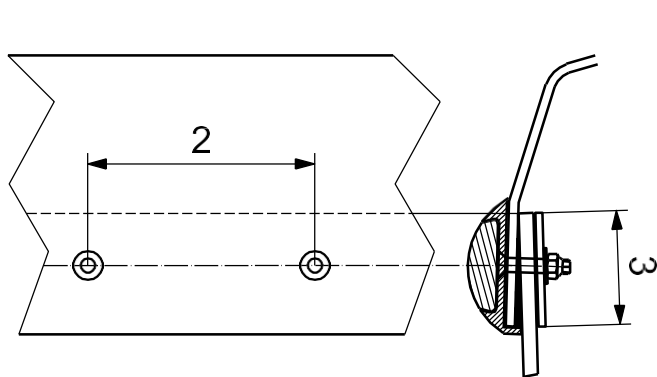

a) Vertical joint

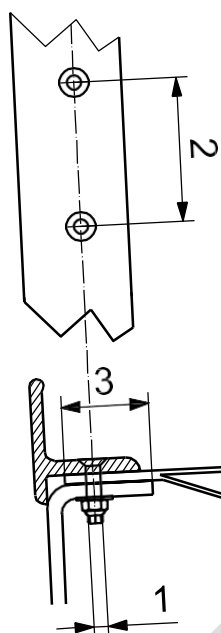
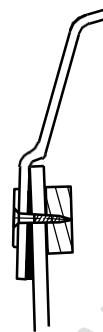

tapping screw and inner wood or plywood cleat

c) Horizontal inboard joint at deck level

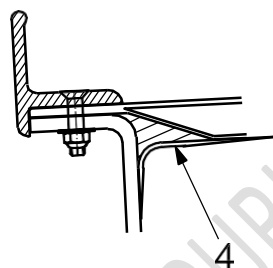

d) Horizontal outboard lipped joint at deck level

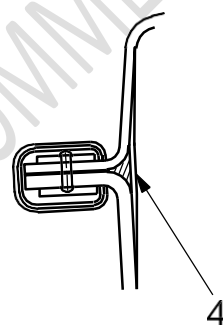

e) Horizontal

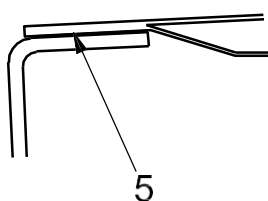

**f) Horizontal joint  
glued only**

Figure 13: Typical hull-deck joints

**7.3.2 Centreline joint**

Where the hull is built in two halves, these shall be connected by staggered and overlapping consecutive layers of laminate. Special attention shall be paid to proper surface preparation before joining.

The connection procedure shown in Figure 14 and explained below is a recommended good practice, for a hull thickness  $t$  excluding eventual protective keel.

The near centreline is tapered by grinding at a ratio 15/1. The half hulls are then connected with continuous plies of a laminate of similar composition to the one of the hulls, and a total width, in mm, of  $76t$  and a thickness  $t$  before progressive diminution [ $76 = 2 \times (15 + 20 + 3)$ ] mm.

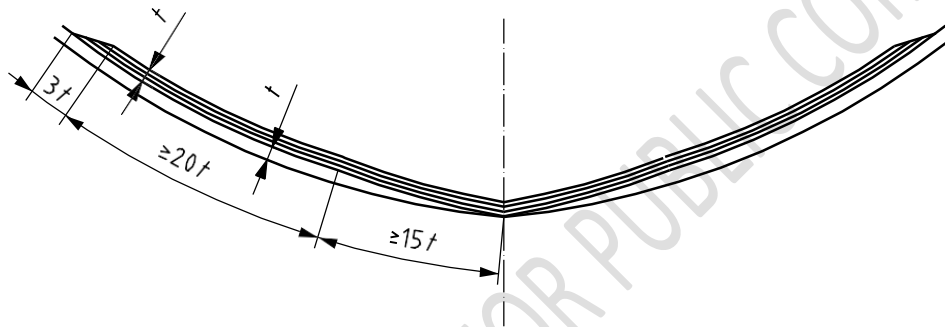

**Key**

$t$  hull thickness

**Figure 14: Centreline joint sketch**

**7.3.3 Transoms for outboard engine and sterndrive installation**

The transom design shall ensure that the bending moment and thrust from the outboard engine or sterndrive is transmitted into the hull structure without creating excessive stress.

Sterndrive transoms shall be stiffened by brackets or any arrangements transmitting the engine and strut loads to the structure. Figure 15 gives examples of typical transom structural configuration. Where relevant, the instructions of the engine manufacturer shall be considered.

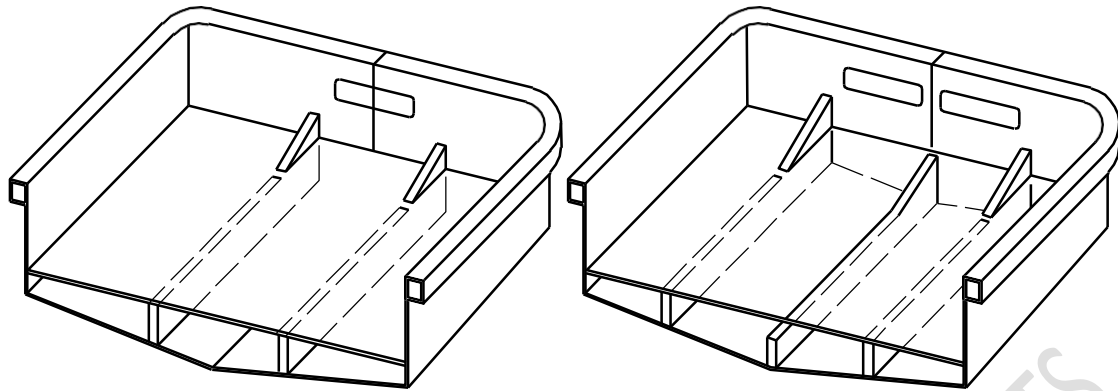

a) Transom reinforced by two bottom girders for single engine

b) Three girders for twin engines

Figure 15: Examples of transom configuration

The minimum thickness of the plywood core,  $t_{\text{plywoodcore}}$ , expressed in mm, is calculated according to Equation (6), and the value obtained shall be rounded to the closest multiple of 5 mm:

$$t_{\text{plywoodcore}} = 35 + 0.15P$$

The minimum thickness of the inner skin of engine support,  $t_{\text{inner}}$ , expressed in mm, is calculated according to Equation (7):

$$t_{\text{inner}} = L_H^{0.55}$$

The minimum thickness of the outer skin of engine support,  $t_{\text{outer}}$ , expressed in mm, is calculated according to Equation (8):

$$t_{\text{outer}} = L_H^{0.55} + 0.085P^{0.5}$$

where  $P$  is the total engine power installed on the transom, in kW. These values are only valid for outboard engine  $P < 100$  kW.

Other arrangements are possible, provided the engine loads are efficiently transmitted to the boat's structure.

#### 7.4. Laminate transition

The transition between adjacent areas of laminates shall be gradual.

In good practice, the length of a transition between laminates of different thickness but of same lay-up is at least 20 times the thickness difference, and in highly stressed areas 40 times the thickness difference. For different lay-up, this is adjusted to the lesser laminate thickness.

Where changes in the hull form occur, such as at the chine or transom boundary, the reinforcement is carried through and past the knuckle, with the ends of the various layers staggered. Good practice reinforcement as given in 7.1.2 may be used (see Figure 10).

#### 7.5. Sandwich construction

Sandwich construction can be regarded as an effective means of limiting deflections. This

construction method may be suitable with or without additional stiffening. Consideration shall be given to the risk of peeling of the outer sandwich skin due to hydraulic pressure. Where a sandwich laminate is transformed into a single skin laminate, it is good practice that the transition zone extend over not less than 3 times the core thickness.

## **7.6. Attachment of fittings**

The hull and/or deck shall be sufficiently strong to carry the load transferred into the boat by fittings such as mooring and towing devices, pulpits, lifeline stanchions, handrails, winches, tracks, blocks, etc.

The reinforcement of the laminate of such fittings shall generally be carried out by the following means:

- a. additional laminate;
- b. backing or insert of plywood or metal reinforcements;
- c. core replacement by high density foam core, wood or plywood insert, possessing compressive strength in the through thickness direction in excess of  $5 \text{ N/mm}^2$ , or transition to single skin laminate; or
- d. a combination of the above.

Where an insert is used in place of the removed core material, the sides of the remaining core and the laminate shall be coated with resin to avoid the ingress of water.

## **7.7. Engine seatings and girders**

### **7.7.1 General**

In addition to the general considerations of 6.3, all supporting structures shall be able to withstand and transmit both the design loads calculated in ISO 12215-5, and superimposed on these loads any additional loads that may occur during its intended service, associated with the engine. These loads may include, but may not be limited to:

- a. the weight of the engine, taking into account any accelerations acting on the engine in the type of usage it is intended for, such as vertical and lateral motions in a seaway, high speed turns, etc.;
- b. the thrust force, if carried by the engine foundation and not by a separately supported thrust bearing;
- c. the torque of the engine and propeller combination;
- d. vibrations caused by the running engine;
- e. the creep of the engine bearers due to constant loading by the engine weight (even when at rest).

These loads are often introduced to the structure as point loads.

Effects of fatigue may need to be considered, particularly near the propeller, where vibrations from pressure fluctuations are frequent.

Engines are usually held by flexible supports to dampen vibrations. The effects of the type of supports on the alignment of the engine and shaft line shall be considered. Where the shaft is supported by a propeller strut, the engine/gearbox/propeller arrangement usually follows one of the arrangements given below, in order to avoid too many degrees of freedom that may bring strong vibration problems:

- a) engine/gearbox on flexible mounts, rigid connection between gearbox and propeller shaft, and "floating" stuffing box and shaft;

- b) engine/gearbox on flexible mounts, flexible connection between gearbox and thrust bearing homocinetic knuckle, and “fixed” stuffing box and shaft.

### 7.7.2 Engine foundations

This subclause describes the most common arrangements. Alternative arrangements may exist that are equally satisfactory. The manufacturer and/or designer shall ensure that the adopted arrangement is suitable for the service for which the craft is intended.

Engines are generally placed in between two longitudinal members, designated as “engine bearers”. These engine bearers provide adequate transmission of engine loads to the surrounding structure. On larger craft, the engine bearers will typically be supported by floors and bulkheads. The engine bearers extend forward and aft in the structure as far as possible, but may be joined together forward and aft of the engine, provided adequate strength and stiffness is maintained. Abrupt changes of height or second moment shall, in general, be avoided as they could cause stress concentration. Where the engine bearers terminate, they shall be suitably sniped or bracketed, or otherwise connected to the structure in a manner to prevent stress concentrations and, where possible, transmit their vertical loads to the structure.

Figure 16 shows typical propulsion engine arrangements that can be used with any material (FRP, plywood, metal). Other arrangements may exist that are equally satisfactory.

Figure 16 a) shows a typical mounting on top of a foam or plywood former. The flexible support block is laid on top of a top hat. It is fixed by bolts tapped in an over-laminated steel plate. If the former is made out of foam, care shall be taken to have the ends of the plate loading the webs in compression, thus not crushing the foam.

Figure 16 b) shows another typical arrangement, where the flexible support is bolted on a flanged angle. This flange angle is bolted on a laminated plywood or metal girder.

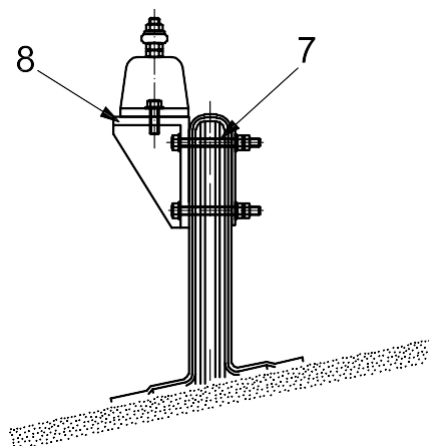
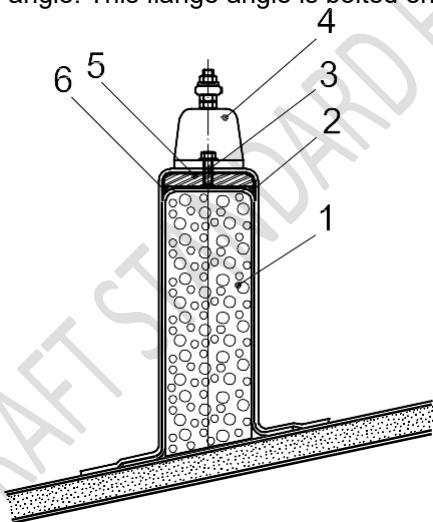

a) Typical mounting on top of foam or plywood former

b) Flexible support bolted on flanged angle

## Key

- 1 foam or plywood former
- 2 the steel plate overhangs the inner web layer for compression loading
- 3 tapped bolt
- 4 flexible engine support
- 5 over-laminated steel plate
- 6 epoxy fillet
- 7 plywood laminated girder
- 8 flanged L metal bracket

a) Figure 16: Examples of typical inboard engine support

### 7.7.3 Foundations of thrust absorbing components such as thrust bearings and saildrives

Thrust bearings, saildrives and similar thrust absorbing components are generally placed between two longitudinal members. These longitudinals shall provide adequate transmission of forces from the thrust absorbing components to the surrounding structure. Forward and aft of these components, the longitudinals may be joined into one. Ideally, the main propulsion engine is placed on the same longitudinals. Where these longitudinals terminate, they are suitably sniped or bracketed, or otherwise connected to the structure in a manner to prevent stress concentrations.

All the supporting structure shall be able to withstand both the design loads calculated in ISO 12215-5, and superimposed on these loads any additional loads that the craft may reasonably be expected to withstand, associated with the thrust absorbing components.

These loads may include, but may not be limited to:

- a. the weight of the unit, taking into account any accelerations acting on the unit in the type of service it is intended for, such as vertical and lateral motions in a seaway, high speed turns, and collisions;
- b. the thrust force;
- c. the hydrodynamic drag force;
- d. the torque of the engine and propeller combination;
- e. vibrations caused by a rotating propeller or by the running engine (transferred through the shaft);
- f. grounding.

These loads may be introduced to the structure as point loads.

### 7.8. Hull drainage

The attachment of stiffeners shall be such that water will not be trapped. Suitable arrangements shall be made to provide free passage of water from all parts of the bilge to the pump suction. Edges of openings in the structure shall be sealed. Limber holes (or penetrations for cables, etc.) shall not be placed close to the flange of frames.

## 8. Specific structural details for metal construction

### 8.1 Design details

Special attention shall be paid to structural continuity. Abrupt changes of shape or section and sharp corners shall be avoided. Where the width of face bar or the depth of web changes, the taper shall not be less than 33 % [see Figure 4 c)].

The detail design of structural members shall ensure that bending moments and forces are suitably transferred at changes in sections. Where considered necessary, ISO 12215-5 and ISO 12215-9 can be used to verify that design shear load and bending moment can be transmitted.

## 8.2 End connections

End connections of structural members shall provide adequate end fixity and effective transmission of the bending moment and shear force into the supporting member, and distribution of the load into the surrounding structure.

### 1.1 Increased hull plating

It is good practice that the thickness of the hull plating in areas subject to chafe or wear, if and where relevant, be increased beyond the minimum required scantlings by at least 0.5 mm.

### 1.2 Protective keel

#### 1.2.1 General

If a boat is designed to be docked on its bottom, it is good practice to fit a protective keel and docking keel. Among protective keels, typical arrangements are bar keel, channel (box) keel, flat (plate) keel, etc.

#### 1.2.2 Protective keel section modulus good practice

If a protective keel is fitted on a metal boat, it is good practice to have its section modulus,  $SM_{KEEL}$ , calculated in  $\text{cm}^3$ , including eventual bar keel and attached plating, not less than

$$SM_{KEEL} = 7 \times 10^{-4} \times f_1 \times m_{LDC} \times L_H$$

where  $f_1$  is as defined in 7.1.2.

Consideration shall be given to buckling of protruding plates or puncturing of flat plates.

In calculating the actual section modulus of the keel, the effective plating shall be in accordance with ISO 12215-5.

### 1.3 Hull drainage

The attachment of stiffeners shall be such that water will not be trapped. Suitable arrangements shall be made to provide free passage of water from all parts of the bilge to the pump suction.

### 1.4 Machinery spaces

Main and auxiliary engines shall be effectively secured to the hull structure by seatings of adequate scantlings to resist the loads listed in 7.7.

### 1.5 Good practice welding standards

#### 1.5.1 General

Many EN or ISO standards contain useful information on welding procedures (see References [4] to [15] in the Bibliography). The application of these procedures is recommended, but not mandatory.

Annex C gives an example of good welding procedure; its application is recommended.

### **1.5.2 Alternative criteria**

The purpose of Annex C is to provide quantitative measures of welding procedures, which may be either adopted by builders or used for benchmarking purposes. Alternative methods of welding are acceptable provided a similar level of strength, longevity, robustness and watertightness to that implied by Annex C is demonstrated either by calculation or by test.

## **1.6 Good practice for riveting or adhesive bonding**

### **1.6.1 General**

Riveting may be used as a structural connection. The good practice outlined in 8.8.3 is valid for all structural riveted connections, and the additional good practice outlined in 8.8.4 is valid for watertight connections.

### **8.2.1 Alternative criteria**

Alternative methods of riveting are acceptable provided a similar level of strength, longevity, robustness and watertightness to that implied by the application of 8.8.3 or 8.8.4 is demonstrated, either by calculation or by test.

### **8.2.2 Good practice for structural riveted connections**

#### **8.2.2.1 Design**

Rivet connections are generally designed to work in shear. Out of plane loads are normally carried by other means. The geometry of the riveted joint ensures that the shear is distributed roughly evenly among the rivets. The shear stress in the rivets may be calculated using the method given in Clause B.2.

The diameter of the rivet is normally at least equal to the thickness of the thickest plate in the connection, or 25 % of the total thickness of connected plates, whichever is the greatest. The distance from the rivet to the edge of the plate is at least 1.5 times the greater plate thickness. The longitudinal and transversal distance between rivets is at least 2.5 times the rivet diameter.

#### **8.2.2.2 Rivet material and type**

The material in the rivet shall preferably be the same as the base material. It shall not turn brittle as a consequence of cold working. The material combination shall be chosen so as to avoid corrosion.

#### **8.2.2.3 Additional good practice for watertight rivet connections**

In watertight connections, the rivets are arranged in two or more rows. The distance between adjacent rivets shall be at most 4 times the thinner plate thickness.

## **9. Good practice on laminated wood**

### **9.1 Edge sealing**

Laminated wood and prefabricated plywood in particular is vulnerable to degradation through water ingress. A sealing coat of resin or other protection shall be employed, including edges. If plywood is to be

used as structurally effective “formers” for FRP stiffeners, then the plywood shall be pre-coated with a suitable resin.

## 9.2 Plywood orientation

The strength and stiffness of plywood consisting of few plies (five or less) is very dependent on the orientation of the face grain. This shall be considered when evaluating scantlings in accordance with ISO 12215-5, especially for:

- a. plywood panels laid up so that the face grain is perpendicular to the short panel direction; in this case, the properties perpendicular to the grain shall be used (see ISO 12215-5:2008, Annex E);
- b. plywood bulkheads with substantial cut outs where the face grain may be at various angles to the local axis of shallow plywood sections (see ISO 12215-5:2008, Annex E).

## 9.3 Local scantlings

### 9.3.1 Protective keel

If a boat is designed to be docked on its bottom, it is good practice to fit a protective keel and docking keel.

### 9.3.2 Protective keel section modulus good practice

If a protected keel is fitted on a wooden or plywood boat, it is good practice to have its section modulus,

$SM_{KEEL}$ , calculated in  $\text{cm}^3$ , including the attached plating, not less than

$$SM_{KEEL} = 2.8 \times 10^{-3} \times f_1 \times m_{LDC} \times L_H \quad (10)$$

where

$$f_1 = \frac{65}{\sigma_{fu}}$$

and  $\sigma_{fu}$  is the ultimate flexural strength of the wood, in  $\text{N/mm}^2$ .

In calculating the actual section modulus of the keel, the effective plating (see ISO 12215-5) shall be 15 times the bottom plating thickness either side of the keel.

### 9.3.3 Protective chine good practice

Where fitted, it is a good practice to have the chine log with a cross-sectional area the greater of  $0.7 \times L^{1.6}_H$  and  $0.12 \times t^2_b$   $\text{cm}^2$

The depth is between 50 % and 60 % of the width and provides a faying surface of at least 2,5 times the thickness of the bottom plating.

Other chine configurations, such as those involving epoxy fillets, are suitable.

## 9.4 Alternative criteria

The purpose of this clause is to provide quantitative measures of robustness, which may be either adopted by builders or used for benchmarking purposes. Alternative methods of local reinforcement are acceptable, provided a similar level of robustness to that implied by this clause is demonstrated either by calculation or by test.

## **10. Consideration of other loads**

In addition to the design pressures and other loads considered in ISO 12215-5, ISO 12215-7, ISO 12215-8

and ISO 12215-9, the following loads shall be considered:

- a. docking (to be based on the normal docking weight of the craft);
- b. lifting (to be based on the normal lifting weight of the craft and number of lifting points);
- c. grounding (see ISO 12215-9);
- d. towing (to be based on minimum speed with regard to steerage, wind and tide);
- e. anchoring;
- f. berthing/mooring;
- g. transportation by road vehicle.

These loads are not explicitly defined in ISO 12215 and may in some cases be difficult to calculate. Nevertheless, adequate local reinforcement shall be provided in due consideration of the above.

These loads

are local and shall be effectively transmitted into the hull structure.

## **11. Other structural components**

### **11.1 General**

Some structural components have explicit scantling formulae given in ISO 12215-5, ISO 12215-7, ISO 12215-8 and ISO 12215-9 (i.e. hull structure, rudder, keel, chainplates, cross-beams), but some other components not covered also need to be considered.

### **11.2 Rudder structure and connection**

See ISO 12215-8.

On spade rudders, the stock is normally held in two points to avoid statically indeterminate structure:

- a low point, usually near the bottom hull, and
- a top point, usually near the deck or on an intermediate console.

On these low and top points, the shell, deck or console shall be strong enough, or be reinforced, to transfer the lateral/vertical loads from the stock (i.e. loads for rudder bearing or pintle fitting).

Where a rudder is attached to the transom, the latter shall be adequately reinforced to take the loads from the rudder or its fittings.

### **11.3 Keel attachment**

See ISO 12215-9

### **11.4 Introduction and distribution of rigging loads See ISO 12215-9.**

See ISO 12215-9

### **11.5 Other structural components not considered in other parts**

Where calculations are not possible, the general requirements of this part of ISO 12215 shall be employed. In particular, the calculable scantlings from other parts of ISO 12215 for the adjacent structure shall provide a reference baseline for assigning scantlings to the following components:

- a. skegs (see ISO 12215-9);
- b. propeller struts;
- b. davits;

- c. windows (see ISO 12216);
- d. ventilation devices (air pipes, vent pipes);
- a. radar masts.

## **Annex A (normative) Structural arrangements for category C and D boats**

### **A.1 General**

This annex concerns the requirements for structural arrangements for boats of design category D or C that are eligible to use ISO 12215-5:2008, Annex A, as specified in Clause 5 of this part of ISO 12215. Such boats may be constructed from fibre reinforced plastics with single or sandwich skins, aluminium or steel alloys, plywood, strip-plank wood or moulded wood laminate.

### **A.2 Hull strength and stiffening**

#### **A.2.1 Plating thickness and local stiffening**

The hull, deck and deckhouse plating shall meet the minimum thickness requirements of ISO 12215-5:2008, Annex A. To determine the minimum plating thickness required by ISO 12215-5:2008, Annex A, the local panel width for the plating “b” shall be known, where b is measured between “stiffeners” at the edges of the panel. These stiffeners may be conventional stiffeners, bulkheads, internal structure such as thwarts or bunk fronts, internal mouldings or “natural” stiffeners such as hull chines, round bilge, deck edge, keel, etc. The measurement of b for typical stiffening arrangements and natural stiffeners is shown in ISO 12215-5:2008, Clause 7.

In order to be considered as a stiffener for this purpose, the stiffener structure shall be “load bearing”. This means that the stiffener shall have sufficient strength such that any flexing of the skin panels shall be between stiffeners, i.e. the stiffener would not flex significantly with the panel. For stiffener frames or stringers of GRP, wood or metal of conventional shape, the minimum dimensions for adequate stiffness can be determined from ISO 12215-5:2008, Annexes A and G.

These load bearing stiffeners shall be effectively attached to the adjacent plating by mechanical fastening, bonding, fibre reinforcement, taping, welding or any method appropriate to the materials. The attachment of the stiffener to the hull plating shall also be made in a way that minimizes any point loads that could lead to local plating distortion (see notes on construction materials below).

Examples of good practice are given below; other arrangements may be chosen provided the necessary overall rigidity is achieved.

#### **A.2.2 Overall rigidity of hull structure**

##### **A.2.2.1 General**

Compliance with the skin thickness requirements of ISO 12215-5:2008, Annex A, should ensure adequate local stiffness of the structure, but further structural consideration may be needed to ensure that the overall rigidity of the hull structure is sufficient to prevent any distortion leading to possible structural damage.

Examples of good practice are given below, as appropriate for the type of decking, other arrangements may be chosen if they provide the necessary overall rigidity.

#### **A.2.2.2 Open boats good practice**

Boats without decking have additional structural material at the perimeter of the hull shell, such as a gunwales/rubbing strake, flange or moulding, to stiffen the top edge of the hull shell. At discontinuities around the perimeter (e.g. at transom corner), the structure is strengthened with additional material, knees or a suitable radius.

For small open boats, the thwart(s) may be used to provide additional transverse rigidity, in which case the ends shall be effectively attached to the hull shell in a way that distributes the load to avoid a point load and distortion (see Figure 3).

#### **A.2.2.3 Partially-decked boats good practice**

For partly-decked boats, the deck shall be effectively attached to the hull shell to prevent local movement, and shall be supported in a way that prevents point loads on the hull shell (see 6.3).

Sharp corners in the deck are avoided to prevent areas of high stress that may lead to cracking (see 6.3).

#### **A.2.2.4 Fully-decked boats good practice**

For fully-decked boats, the hull and deck structure shall be arranged to prevent the deck from moving independently from the hull. For boats with interior space, this is typically achieved by a combination of bulkheads or partial bulkheads, webs, beams, ring frames or struts.

For small fully-decked boats where the internal space between the hull and deck is not easily accessible, sufficient rigidity may be achieved by bonding or otherwise connecting areas of the hull to the deck or cockpit floor either directly or via an internal structure designed for this purpose.

#### **A.2.3 Distribution of loads**

The structural arrangement shall ensure a smooth transfer of loads throughout the structure. Good practice is as follows:

- a. stiffeners do not terminate abruptly, but are continuous into other stiffening structure to avoid any concentrated load points, or they have tapered ends;
- b. concentrated point loads are not landed on unsupported plating; they are transmitted into the surrounding structure by reinforcement or supporting members;
- c. openings in the hull shell, deck or other load-carrying structures have radius corners; sharp corners are avoided (see 6.3.3).

**Annex B**  
**(informative)**  
**Determination of shear stresses within a stiffener with glued or riveted joints**

**B.1 General**

The contents of this annex are an application of the method of stiffener analysis given in ISO 12215-5:2008, Annexes G and H. Consequently, only specific items regarding the stiffener connection are covered here.

**B.2 Shear stress and shear flow within a stiffener**

The example of top hat given in ISO 12215-5:2008, Annex H, is used.

Dimensions in millimetres

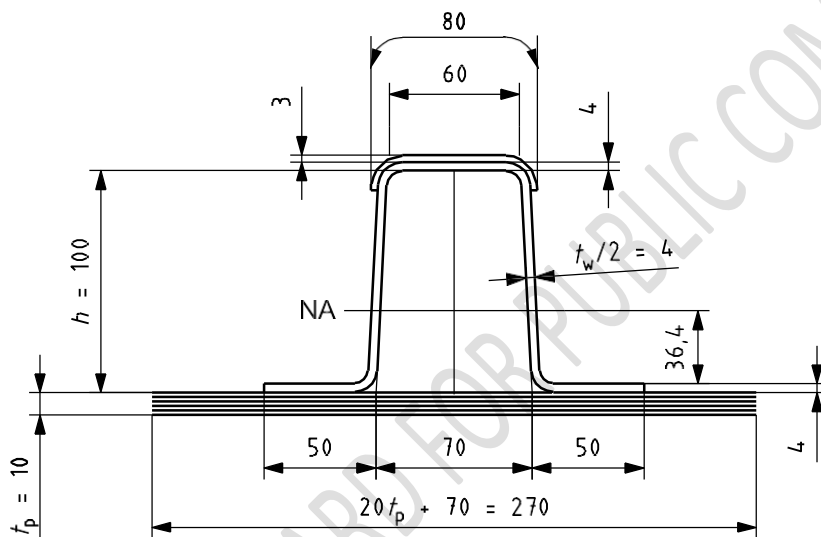

Key

- NA neutral axis
- h height of stiffener
- t<sub>p</sub> plate thickness
- t<sub>w</sub> total thickness of top hat web

Figure B.1: Top hat

The shear flow,  $q$ , expressed in N/mm, is defined in ISO 12215-5:2008, H.2.1.6.

For a 1 mm wide strip of plating,

$$q = F \frac{Q \times E}{E \times I_{NA}} \quad (B.1)$$

and for a stiffener,

$$\sigma = \frac{F \times E \times A \times z_{CANA}}{E \times I_{NA}}$$

where

$F$  is the maximum shear force, in N;

$Q$  is the first moment of area, in mm<sup>3</sup>;

$E$  is the inplane elastic modulus of the stiffener element, in N/mm<sup>2</sup>;

$E \times I_{NA}$  is the flexural rigidity of the stiffener and plating combined around the neutral axis, in N/mm<sup>2</sup>;

$A$  is the cross-sectional area from the point to an outer edge of the stiffener, in mm<sup>2</sup>;

$z_{CANA}$  is the height of the centroid of  $A$  to the neutral axis, in mm.

In ISO 12215-5:2008, Table H.4, Column 23, the shear flow varies from 0 N/mm at top or bottom ends of the stiffener, to 255 N/mm at NA (neutral axis) and is 225 N/mm at the bonding between plating and flange.

As in ISO 12215-5, Table H.4, of prime importance is the strength of the laminated or glued bond. The average shear stress within the bottom flange,  $\tau_{ave}$ , calculated in N/mm<sup>2</sup>, is:

$$\tau_{ave} = \frac{225}{100} = 2.25$$

and the compliance factor,  $c_f$ , is:

$$c_f = \frac{\tau_d}{\tau_{ave}} = \frac{225}{100} = 2.25$$

### B.3 Design shear stress in a laminated or glued bond

In the method described in this annex, given the importance of the strength of the glue bond, the first step is to assess what the design stress is within a laminate or a glue bond.

Stress distributions in laminated or glued bonds are complex. Equations (B.1) to (B.4) above for shear flow and stress are simplifications and do not allow for stress concentrations. In addition, the visco-elastic nature of adhesives requires that design stresses be kept low in order to limit creep and ensure longevity of the bond.

For these reasons, the design strength in a bond requires a higher safety factor than in other structural materials such as FRP, wood or metal.

Therefore the design shear stress in the bond,  $\tau_{dbond}$ , calculated in N/mm<sup>2</sup>, is:

$$\tau_{dbond} = 0.2\tau_{ubond}$$

where  $\tau_{ubond}$  is the ultimate shear strength in the bond.

Data may be taken from Table B.1 unless specific tested values are available.

**Table B.1 — Nominal and design shear stress in a laminated or glued bond**

Adhesive	Ultimate shear strength in bond	Design shear stress in bond
	$\tau_{ubond}$ N/mm <sup>2</sup>	$\tau_{dbond}$ N/mm <sup>2</sup>
Polyester or vinylester resin or paste	15	3
Cold-cured epoxy	27	5,4
Epoxy type paste	40	8

In ISO 12215-5:2008, Table H.4, the bottom part of the table concerns this bond strength. With polyester resin laminate or paste, design shear stress in the bond is 3 N/mm<sup>2</sup>, as indicated in Table B.1 above. Consequently, the compliance factor,  $c_f$ , is an acceptable value

$$C_f = \frac{\tau_{dbond}}{\tau_{avebond}} = \frac{3}{2.24} = 1.33$$

For other glued stiffeners, particularly wooden ones, the same method shall be used to evaluate the strength of a glued bond. However, the proportions of the stiffeners given in ISO 12215-5:2008, Annex G, are such that glued bond stress is not usually critical.

#### B.4 Values of $k_j$

The values of  $k_j$  defined in 7.2.3.4 have been computed in Table B.2, using the two first values of glued bond of Table B.1 for interlaminar shear design stress of the glue/paste, and the default values of ISO 12215-5:2008, Tables C.4 a) and C.4 b), for the webs. The values of  $\tau_d$  and  $k_j$  have been rounded to the closest integer figure;  $b_a$  is the bondline width.

NOTE In ISO 12215-5:2008, Table H.4, it can be observed that the shear flow at the bond (225 N/mm) is slightly lower than at NA level (255 N/mm), and the values given in Table B.2 are slightly conservative.

**Table B.2 — Ultimate and design bond strength**

Polyester or vinylester glue resin/glue/paste							Cold cured epoxy glue resin/glue/paste						
$\tau_d$ laminate, glue or paste from Table B.1	Values of $b_a / t_w$ for $\tau_d$ glue						$\tau_d$ laminate, glue or paste from Table B.1	Values of $b_a / t_w$ for $\tau_d$ glue					
	Interlaminar shear ISO 12215-5:2008, Annex C			Value of $k_j$ in 7.2.3.4				Interlaminar shear ISO 12215-5:2008, Annex C			Value of $k_j$ in 7.2.3.4		
3.0							5,4						
$\psi$	MR <sup>a</sup> $\tau_d$	DB $\pm 45^\circ$ $\tau_d$	Quad <sup>c</sup> $\tau_d$	MR	DB $\pm 45^\circ$	Quad	$\psi$	MR $\tau_d$	DB $\pm 45^\circ$ $\tau_d$	Quad $\tau_d$	MR	DB $\pm 45^\circ$	Quad
	N/mm <sup>2</sup>							N/mm <sup>2</sup>					
0.35	33	59	36	11	20	12	0.35	33	59	36	6	11	7
0.40	35	63	39	12	21	13	0.40	35	63	39	6	12	7
0.45	37	67	41	12	22	14	0.45	37	67	41	7	12	8
0.50	39	70	43	13	23	14	0.50	39	70	43	7	13	8
0.55	41	74	45	14	25	15	0.55	41	74	45	8	14	8
0.60	43	77	47	14	26	16	0.60	43	77	47	8	14	9

NOTE Significant results are shaded dark.

- a MR = mat/roving.  
 b DB ± 45 = double bias ± 45°.  
 c Quad = balanced quadraxial (0/45/90/-45).

## B.5 Rough assessment of shear flow

An approximate method to assess the shear flow is to divide the shear force,  $F_d$ , by the height between the CGs of the top and bottom flange. This method may be used for preliminary calculation only.

In the case of the example of ISO 12215-5:2008, Table H.4, the total height is 121 mm, from which half the thickness of the two top flanges is deducted ( $7/2 = 3.5$  mm) plus half the thickness of the bottom flange, the plating ( $10/2 = 5$  mm). The height for rough evaluation is then  $121 - 3.5 - 5 = 112.5$  mm. The “rough” shear flow,  $q$ , expressed in N/mm, is calculated as

$$q = \frac{F_d}{h_{eq}} = \frac{26\,950}{112.5} = 240 \text{ N/mm}$$

which is in between the maximum value at 255 N/mm and the value at bond flange at 225 N/mm.

This value may be used for a rough assessment of the glue joint, or multiplied by 1.10 for a more conservative assessment.

## B.6 Determination of riveted joints

### B.6.1 Theory

After calculating the shear flow, as explained above for a glued joint, the force on each rivet,  $f_r$ , expressed in N, is calculated by Equation (B.6):

$$f_r = \frac{q \times s_r}{n_r}$$

where

- $s_r$  is the rivet spacing, in mm;
- $n_r$  is the number of rivets per row.

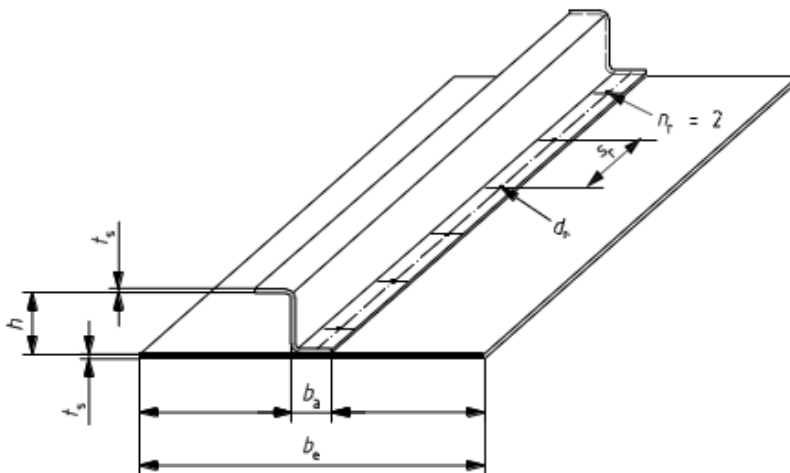

**Key**

- $b_a$  bondline width
- $b_e$  effective width of attached plating
- $d_r$  rivet diameter
- $h$  height of centre of panel or middle of stiffener above the fully loaded waterline
- $n_r$  number of rivets per row
- $s_r$  rivet spacing
- $t_s$  stiffener flange thickness

**Figure B.2: Riveted stiffener sketch****B.6.2 Design criterion**

The force per rivet,  $f_r$ , shall not be greater than the design force that the rivet can transmit, which is the smallest of the results of Equations (B.7), (B.8) and (B.9) below.

The force per rivet in the shear,  $f_{rs}$ , expressed in N, is

$$f_{rs} = \frac{\tau_d \times \pi \times d_r^2}{4}$$

The force per rivet in the bearing of the rivet in the bottom flange of the stiffener,  $f_{rbstiff}$ , expressed in N, is

$$f_{rbstiff} = 1.8 \times \sigma_d \times d_r \times t_s$$

The force per rivet in the bearing of the rivet in the plating,  $f_{rbplate}$ , expressed in N, is

$$f_{rbplate} = 1.8 \times \sigma_d \times d_r \times t_p$$

where

- $d_r$  is the rivet diameter, in mm;
- $\tau_d$  is the design shear stress on the rivet according to ISO 12212-5 for stiffeners, in N/mm<sup>2</sup>;
- $\sigma_d$  is the design tensile stress on the stiffener according to ISO 12212-5 for stiffeners, in N/mm<sup>2</sup>;
- $t_s$  is the stiffener flange thickness, in mm;
- $t_p$  is the plate thickness, in mm.

**B.6.3 Worked example**

The worked example shown in Tables B.3 and B.4 analyses the case of a 3 mm thick aluminium stiffener riveted on a 4 mm aluminium plating and stiffener, both made from EN AW 5083 H 111, and rivets made from EN AW 5383 H 34 (See ISO 12215-5:2008, Table F.1).

**Table B.3: Riveted connection calculation**

Main data			Analysis of the rivets			Analysis of the stiffener flange		
Shear flow $q$	100,0	N/mm	Shear stress in rivet $\tau$	70.7	N/mm <sup>2</sup>	—	—	—
Rivet diameter	6	mm	Compliance factor in shear $\tau_d/\tau$	1.07	—	—	—	—
Rivet spacing	40	mm	Bearing thickness	3.0	mm	Bearing thickness	3.0	mm
Nb of row	2	—	Bearing stress on rivet	111	N/mm <sup>2</sup>	Bearing stress on flange	111	N/mm <sup>2</sup>
Required force/rivet	2 000	N	Comp. factor in bearing $\sigma_{db}/\sigma$	2.12	—	Comp.factor in bearing $\sigma_{db}/\sigma$	1.83	*

**Table B.4 — Rivet and plate mechanical properties in accordance with ISO 12215-5:2008, Table F.1**

Property	Rivet material EN AW 5383 H 34			Stiffener material EN AW 5083 H 111		
Tensile	$\sigma_d$ rivet	131	N/mm <sup>2</sup>	$\sigma_d$ rivet	113	N/mm <sup>2</sup>
Shear	$\tau_d$ rivet	76	N/mm <sup>2</sup>	$\tau_d$ rivet	65	N/mm <sup>2</sup>
Bearing	$\sigma_{db}$ rivet = 1.8 $\sigma_d$ rivet	236	N/mm <sup>2</sup>	$\sigma_{db}$ rivet = 1.8 $\sigma_d$ rivet	203	N/mm <sup>2</sup>

In this example, the importance of the shear flow requires two rows of rivets with a 6 mm diameter. The limiting condition is the rivet shear stress, with the compliance factor in shear just above 1. The bearing condition is not critical.

## Annex C (informative) Good practice welding procedure

### C.1 General

The steel and aluminium materials shall be in accordance with ISO 12215-3 or with ISO 12215-5:2008, Annex F.

Welded joints shall be designed to be accessible to ensure sound welding and for easy inspection. Relevant details shall be indicated in the welding schedule that shall be completed and available before construction starts.

The sequence of welding plate butt welds and the fillet welds of structural elements to the plating shall be such as to minimize residual stresses and deformation of the structure. The welding sequence shall be completed and available before construction starts.

The fit-up of plating and structural elements shall correspond accurately to the welding schedule. Design details to ensure that the gaps between the plates and members being attached are as designed to produce sound welds.

The welded joints shall be designed to provide a smooth flow of stresses as far as practicable without abrupt changes in section, or thickness and without structural notches.

The change in depth of web or width of face bar or flange of members shall not exceed 1 in 3.

Where the difference in thickness of abutting plates exceeds 3 mm, the thicker plate shall be tapered to a slope not exceeding 1 in 3.

Doublers shall generally be avoided but, where used, shall not be thicker than 1.5 times the thickness of the plating to which they shall be attached. They shall be attached by continuous fillet welds around the edges of the doubler and as necessary around the edges of slots in the doubler.

Local accumulation of welding shall be avoided. Butt welds shall be at least  $(50 \text{ mm} + 4t)$  apart and butt welds shall be at least  $(30 \text{ mm} + 3t)$  from fillet welds, where  $t$  is the thickness of the weld.

Openings made in the webs of structural members for subsequent butt welds or fillet welds shall have a radius of not less than 25 mm or  $2t$ , whichever is greater. The fillet welds shall be wrapped around the edges of all such openings.

## **C.2 Welding processes**

### **C.2.1 Steel welding**

Steel plates and structural members shall be welded by manual metal arc (MMA) or submerged arc (SAW) welding. Other processes, such as metal inert gas (MIG) or tungsten inert gas (TIG), laser welding or plasma arc welding, may be considered.

### **C.2.1 Aluminium welding**

Aluminium plates and structural members shall be welded by metal inert gas (MIG) or tungsten inert gas (TIG) methods. Other processes, such as friction stir welding and laser welding, may be considered.

## **C.3 Cleanliness of surfaces**

### **C.3.1 Steel elements**

All surfaces to be welded shall be free of moisture, grease, loose mill scale, rust, paint or other contaminants by wire brushing or grinding.

Primer coatings may exist, provided it is demonstrated that they have no adverse effect on the quality of the welds.

Slag and scale shall be removed from the edges to be welded and also from each pass before depositing the subsequent pass.

### **C.3.2 Aluminium elements**

Suitable solvents or mechanical means shall be used to remove oil, grease, indelible markings and all other contaminants from the vicinity of the area to be welded.

Oxide films shall be removed from joint surfaces immediately prior to welding by suitable mechanical or chemical means.

## **C.4 Butt welds**

### **C.4.1 General**

All plate butt welds shall be full penetration, welded from both sides, although plates with a thickness 2 mm may be welded from one side only. Initially the butt weld shall be made from one side, following which the weld shall be back-chipped to sound weld metal from the unwelded side, cleaned and the weld completed

Plate butt welds may be made from one side only, provided backing bars of the same material as the materials being welded are provided and the details are shown in the welding schedule.

The following are general recommendations for edge preparation for butt welds.

### **C.4.2 Edge preparation – steel plates**

- The following generally applies for MMA, SAW, MIG and TIG welding processes:
- square plate edges: maximum thickness is 6.5 mm for manual welding; 19 mm for automatic welding;
- single vee (60° included angle): maximum thickness is 19 mm for manual welding; 25 mm for automatic welding;
- double vee (60° included angle): unlimited thickness.

### **C.4.3 Edge preparation – aluminium plates**

The following generally applies for MIG and TIG welding processes:

- square plate edges: maximum thickness is 6 mm;
- single vee (80° included angle): maximum thickness is 25 mm;
- double vee (80° included angle): unlimited thickness.

#### **C.4.4 Root gaps and root faces**

Root gaps between plates and root faces shall be suitable to provide access for the electrode or wire to ensure a sound weld.

#### **C.4.5 Fillet welds**

##### **C.4.5.1 General**

Structural members shall be attached to the shell, deck or bulkhead plating, and bulkheads shall be attached to the shell and deck by fillet welds.

Fillet welds of high local stresses, e.g. load transfer zones, such as end connections, bracket connections and other type of support providing connections, shall be continuous on both sides of the members, e.g. double continuous fillet welds of throat size obtained using  $\frac{C_W}{C_W} = 1.0$  in Equation (C.1).

Double continuous fillet welds are also recommended in corrosion vulnerable locations, e.g. bilges, water tanks, bottom of fuel tanks or in spaces or locations where condensation, spray or leakage water can accumulate.

In all locations where double continuous fillet welds are recommended, the fillet welds shall be continued around the ends of stiffeners or cut-outs to seal all edges.

In less highly loaded locations that are not vulnerable to the effects of corrosion, staggered intermittent fillet welding may be used.

Where staggered intermittent welding is used, the minimum length of weld shall be not less than 10 t but need not exceed 75 mm and the maximum unwelded distance on any one side of the plate shall not exceed 25 t.

Where the gap between members of a tee connection exceeds 1 mm, the fillet weld leg size shall be increased by a length equal to the gap minus 1 mm.

### C.4.5.2 Fillet weld end connections

Where structural members are attached to brackets, the arm length of the welded connection of the member to the bracket shall generally be not less than 1,5 times the depth of the member. The connection shall be made by double continuous fillet welds of throat size not less than that given by Equation (C.1).

The lap of the bracket onto the member perpendicular to the arm length shall generally be not less than 25 mm, or of depth as required to provide adequate access for a weld all around the overlap.

Where end connections are made without brackets and where the member is butted onto the supporting member, all elements that were taken as effective in calculating the required section modulus, e.g. web and flange, shall be attached to the supporting member by double continuous fillet welds of throat size not less than that given by Equation (C.1).

Where a structural member is lapped onto another structural member without a bracket, the members shall be connected all around the overlap by double continuous fillet welds of throat size not less than that given by Equation (C.1). In such cases, the total area of the weld shall generally not be less than the sectional area of the smaller member.

### C.4.5.3 Fillet weld sizes

Fillet welds shall be triangular in transverse section with the leg of the fillet weld,  $w$ , being the length of the attachment of the fillet weld onto each of the members being connected (see Figure C.1). The strength of the fillet weld is based on the throat dimension,  $a$ , of the fillet weld.

The throat size of the fillet weld depends on the thickness of the member being attached and the zone in which the weld is being made, e.g. high load zone or lower load zone.

The basic fillet weld throat size,  $a$ , expressed in mm, shall not be less than as calculated in Equations (C.1) and (C.2) (see Figure C.1):

$$a \geq 0.70 \times t \times C \times \frac{s_w}{l_w} + 1$$

$$a \geq 0.70 \times w$$

where

$t$  is the thickness of member being attached, in mm;

$C$  is the weld factor given in Table C.2;

$l_w$  is the length of staggered intermittent weld clear of crater, in mm;

$s_w$  is the distance between centres of staggered intermittent welds, in mm;

$w$  is the fillet weld leg size, in mm.

The throat size shall not be less than that required by Equation (C.1) or that given in Table C.1, whichever is the greater.

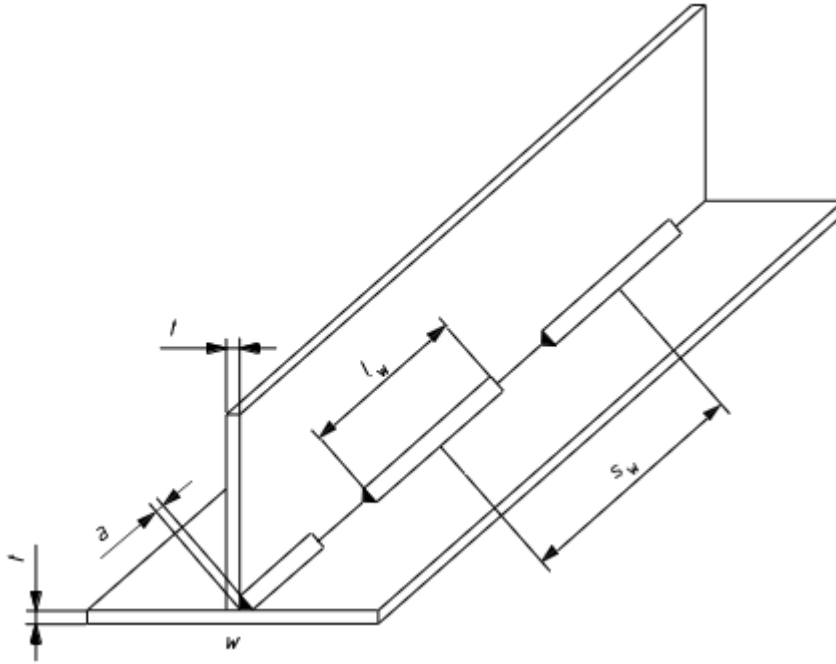

**Key**

- $a$  throat dimension of fillet weld
- $l_w$  length of staggered intermittent weld clear of crater
- $s_w$  distance between centres of staggered intermittent welds
- $t$  thickness of member being attached
- $w$  fillet weld leg size

**Figure C.1 — Intermittent fillet weld dimensions**

**Table C.1: Minimum throat size of fillet weld**

Thickness of plate being attached $t$ mm	Minimum throat size of fillet weld $a$ mm
$t \leq 3$	2.0
$3 < t \leq 4$	2.0
$4 < t \leq 5$	2.5
$5 < t \leq 10$	3.0
$10 < t \leq 15$	3.5
$15 < t$	4.0 or $(0.20 \times t)$ , whichever is greater

**C.4.5.4 Total length of intermittent welds**

It is good practice to have the total welded length of intermittent length not less than:

- 50 % of total length for connections in hull bottom and side, including integral tanks;
- 40 % of total length for connections elsewhere.

The fillet weld size shall comply with the requirements of Table C.1 or Table C.2, whichever is the greater. At the end of all stiffeners, the welds are double continuous for 75 mm from the end.

#### C.4.6 Welder qualification tests

Welder qualification tests shall be carried out for butt welds using the plate edge preparation, gaps between plates, root face dimensions and weld positions to be used in production welding, and as indicated in the welding schedule. Fillet weld qualification tests shall be carried out using the details and welding positions to be used in production and indicated in the welding schedule

The quality of the resulting welds shall be verified by non-destructive or destructive testing.

Departures from the edge preparations indicated in C.4.2 and C.4.3 may be accepted based on satisfactory welder qualification tests.

**Table C.2: Weld factor**

Structural member		Weld factor	
		Steel	Aluminium
Floors, bottom transverses and bottom girders	To bottom shell	0.16	0.18
	To bottom shell by way of propellers, shaft struts and machinery	0,25 DC <sup>a</sup>	0.25 DC <sup>a</sup>
	To inner bottom or face bars	0.12	0.14
Floors and bottom transverses	To bottom girders	0.30 DC	0.30 DC
Bottom girders	To bulkheads, transverses or floors	0.30 DC	0.30 DC
Frames	To shell	0.14	0.16
	To shell by way of propellers, shaft struts and machinery	0.25 DC	0.25 DC
	To inner bottom or face bars	0.12	0.14
Girders, transverses and stringers	To side shell	0.14	0.16
	To deck and bulkheads by way of tanks	0.16	0.18
	To deck and bulkheads clear of tanks	0.14	0.16
	To face bar		
Beams, longitudinals and stiffeners	To deck	0.12	0.14
	To tank boundaries and house fronts	0.12	0.14
	To watertight bulkheads and house sides and ends	0.12	0.14
Engine foundations	To shell and face bar	0.40 DC	0.40 DC
Bulkheads and tank boundaries	Non-tight internal	0.14	0.16
	Watertight or exposed to weather	0.38 DC	0.38 DC
	Tank boundaries	0.40 DC	0.40 DC

Decks	Non-tight internal boundaries	0.25	0.25
	Weathertight boundaries	0.38 DC <sup>b</sup>	0.38 DC <sup>b</sup>
	Strength deck boundaries	0.38 DC <sup>b</sup>	0.38 DC <sup>b</sup>
All end connections	Members to brackets	0.40 DC	0.40 DC
	Brackets to shell, decks or bulkheads	0.40 DC	0.40 DC
	Members directly to other members, without brackets	0.50 DC	0.50 DC
	Chain plates to shell, or other members	0.50 DC	0.50 DC
Rudders	Internals to side plating	0.30	0.30
	Horizontal internals to rudder stock or vertical mainpiece	0.50 DC	0.50 DC
Shaft brackets	To boss and to shell insert	Full penetration	Full penetration
<sup>a</sup> DC: "double continuous welding". <sup>b</sup> Where the thickness of the deck is less than 12,5 mm, the internal weld may be intermittent.			

## Annex D (informative) Longitudinal strength analysis

### D.1 General

It is generally accepted that the scantlings of the types of small craft covered by the scope of the ISO 12215 series are governed by local loads.

Occasionally, hull girder bending (longitudinal strength) calculations should be carried out as indicated in 6.2.

The following procedure is not intended to serve as a full longitudinal strength calculation. Its purpose is to identify craft where local loads may not govern scantlings in all areas. Any craft which does not comply with the criteria set out in this annex is considered to require a more thorough global strength assessment.

Such assessment is outside the scope of this part of ISO 12215 and will require further engineering calculations to be made. The procedure below is limited to assessing the strength of deck structures under sagging moments. These are considered to be the most critical.

### D.2 Maximum bending moment

The maximal vertical bending moment on the hull,  $M_{\text{VHULL}}$ , expressed in N·m, is

$$M_{\text{VHULL}} = k_{\text{GLOB}} \times m_{\text{LDC}} \times L_{\text{H}}$$

where the factor  $k_{\text{GLOB}}$  has the following values:

- for motor craft,  $k_{\text{GLOB}} = 0.5 + 0.6 n_{\text{CG}}$ ;
- for sailing craft,  $k_{\text{GLOB}} = 2.7$ ;

and where  $n_{\text{CG}}$  is the dynamic load factor. The other dimensions are already defined.

The resisting structure to this bending moment shall be assessed in compression for the

deck (generally the limiting factor in longitudinal strength analysis), or in tensile stress for the bottom or the keel.

### D.3 Deck compressive stress

The compressive design stress from global bending,  $\sigma_{DK}$ , expressed in N/mm<sup>2</sup>, is calculated by

$$\sigma_{DK} = M_{VHULL} \times z_{DK} \times \frac{E_{DK}}{EI_{NA}}$$

Where

$z_{DK}$  is the vertical distance from the deck to the neutral axis of the hull girder at the midship section, in mm;

$E_{DK}$  is the (average) elastic modulus of the deck, in N·mm<sup>2</sup>;

$EI_{NA}$  is the flexural rigidity of the hull girder at the midship section, in N·mm<sup>2</sup>, ignoring any deckhouse structure (of the midship section) which has a length of less than  $\frac{L_H}{2}$ .

$\sigma_{DK}$ , expressed in N/mm<sup>2</sup>, shall not be greater than the following values:

- $\sigma_{DK} \leq 0.7\sigma_{YW}$ , where  $\sigma_{YW}$  is the welded yield strength for metals as defined in ISO 12215-5;
- $\sigma_{DK} \leq 0.5\sigma_{UC}$ , where  $\sigma_{UC}$  is the ultimate compressive strength for other materials as defined in ISO 12215-5;
- $\sigma_{DK} \leq 0.8\sigma_{CRX}$ , where  $\sigma_{CRX}$  is the panel buckling critical stress as defined in D.4.
- Figure D.1 explains the relationship between  $z_{DK}$  and  $z_{BOTT}$ , the vertical distance from the neutral axis of the hull girder at the midship section to the bottom of the hull.

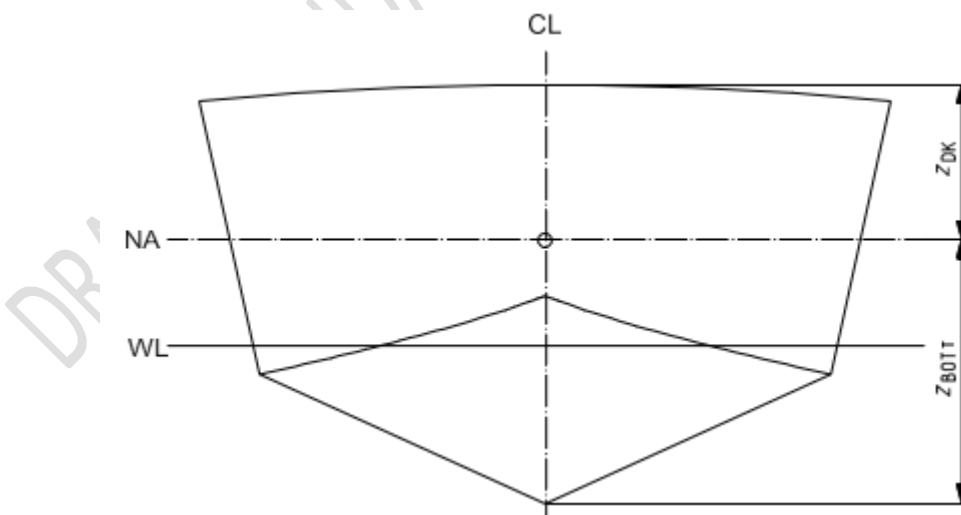

#### Key

- CL centreline
- WL waterline

- NA neutral axis
- $z_{DK}$  vertical distance from deck to neutral axis of hull girder at midship section
- $z_{BOTT}$  vertical distance from neutral axis of hull girder at midship section to bottom of hull

**Figure D.1: Hull and deck section**

## D.4 Deck buckling stress

### D.4.1 General

The determination of the buckling stress of a panel is not straightforward, as the lowest stress for all the buckling modes (number of half waves) shall be checked. This becomes even more complicated for composite materials which are orthotropic and for which the isotropic equations used for metals may not be applicable.

The following method may be used, but finite element (eigenvalue) analysis, using shell or solid elements with boundary conditions corresponding to simple support, may also be used.

When analysing a deck panel in buckling, the dimensions are schematized as shown in Figure D.2.

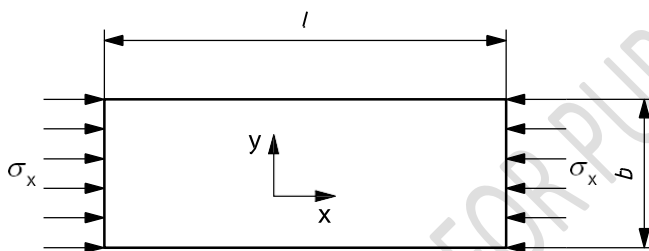

**a) Deck compressive stress parallel to long edge of panel (longitudinal framing)**

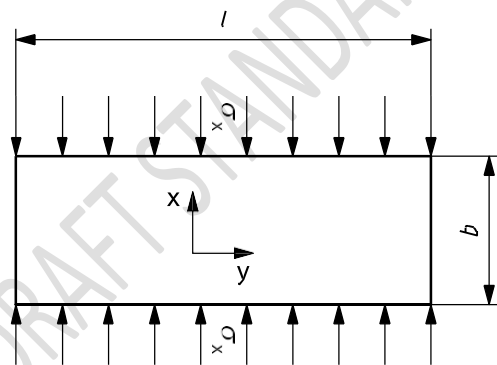

**b) Deck compressive stress parallel to small edge of panel (transversal framing)**

#### Key

- $b$  smallest panel dimension
- $l$  greatest panel dimension
- $\sigma_x$  critical buckling stress along the  $x$  axis

**Figure D.2: Sketch for deck buckling analysis**

## D.4.2 Buckling of metal and isotropic GRP panels

**D.4.2.1** For isotropic panels, the critical buckling stress along the x axis (see Figure D.2) is calculated as shown in Equations (D.3), (D.4) and (D.5).

**D.4.2.2** First, the elastic buckling stress,  $\sigma_{ex}$ , expressed in N/mm<sup>2</sup>, is calculated as in Equation (D.3):

$$\sigma_{ex} = k_e \times E \times \left(\frac{t}{b}\right)^2$$

where the factor  $k_e$  has one of the following values:

- where the compressive stress is parallel to the long edge [normally longitudinal framing/stringers; see Figure D.2 a)],  $k_e = 3.60$ ;
- where the compressive stress is parallel to the small edge of the panel [normally transversal framing, i.e. beams without stringers; see Figure D.2 b) for  $\frac{b}{l} \leq 1$

$$k_e = 0,9 \times \left[ 1 + \left(\frac{b}{l}\right)^2 \right]^2$$

- NOTE: All edges are considered simply supported, which may be slightly conservative in some cases.

**D.4.2.3** For isotropic FRP panels, the critical stress,  $\sigma_{crx}$ , expressed in N/mm<sup>2</sup>, is  $\sigma_{crx} = \sigma_e$ .

**D.4.2.4** For metal panels, the critical stress,  $\sigma_{crx}$ , expressed in N/mm<sup>2</sup>, is calculated by one of the following:

- where  $\sigma_e \leq 0.5\sigma_{YW}$ ,  $\sigma_{crx} = \sigma_e$ ;
- where  $\sigma_e > 0.5\sigma_{YW}$ ,

$$\sigma_{crx} = \sigma_{YW} \times \left( 1 - 0,25 \frac{\sigma_{YW}}{\sigma_e} \right)$$

where  $\sigma_{YW}$  is the yield strength of the plate, in the welded state, in N/mm<sup>2</sup>.

EXAMPLE 1: A deck made of 5083 H111 aluminium alloy has the values  $E = 70\,000$  N/mm<sup>2</sup> and  $\sigma_{yw} = 125$  N/mm<sup>2</sup> (taken from ISO 12215-5:2008, Table F.1). For deck thickness of 4 mm and  $b = 350$  mm,  $l = 1\,000$  mm (stringer spacing 350 mm and beam spacing 1 000 mm),  $\sigma_e = 3.60 \times 70\,000 \times (4/350)^2 = 32.9$  N/mm<sup>2</sup> and as this value is  $\ll 0.5\sigma_{yw} = 62.5$  N/mm<sup>2</sup>,  $\sigma_{crx} = \sigma_e = 32.9$  N/mm<sup>2</sup>, i.e. no correction is required.

The deck stress,  $\sigma_{DK}$ , calculated from Equation (D.2), is not to be greater than

- $0.7\sigma_{yw} = 87.5 \text{ N/mm}^2$ , or
- $0.8\sigma_{crx} = 26.3 \text{ N/mm}^2$ .

**EXAMPLE 2** The same deck plating as in Example 1 is laid on beams spaced 350 mm with no intermediate stringers;  $b = 350 \text{ mm}$ ,  $l = 1\,000 \text{ mm}$ . From Equation (D.4),  $k_e = 0.9 \times [1 + (350/3\,000)^2]^2 = 0.92$  and  $\sigma_e = 0.92 \times 70\,000 \times (4/350)^2 = 8.5 \text{ N/mm}^2$  and as this value is  $\ll 0.5\sigma_{yw} = 62.5 \text{ N/mm}^2$ ,  $\sigma_{crx} = \sigma_e = 8.5 \text{ N/mm}^2$ .

The deck stress,  $\sigma_{DK}$ , calculated from Equation (D.2), is not to be greater than

- $0.7\sigma_{yw} = 87.5 \text{ N/mm}^2$ , or
- $0.8\sigma_{crx} = 6.8 \text{ N/mm}^2$ .

From this example, it is apparent that deck plating laid only on beams cannot support large loads before buckling, and that longitudinal deck stringers significantly increase the resistance of the deck structure to buckling induced by the bending moment of the hull.

The low elastic modulus of E-glass single skin side decks makes this component particularly at risk from buckling, and a simple check using the method described in this annex is strongly recommended.

#### D.4.3 Buckling of an orthotropic FRP panel

For a single skin composite orthotropic material, the formulae are much more complex than for metal.

For example, the formula for a single skin symmetric, special orthotropic laminates with  $[B] = 0$ ,  $D_{16} = D_{26} = 0^*$  (i.e. the laminate stack shall be symmetrical about the mid-plane and composed of 0/90 plies with reference to the panel sides).

For especially orthotropic laminates, the critical stress,  $\sigma_{crx}$ , expressed in  $\text{N/mm}^2$ , is calculated by:

$$\sigma_{xCR} = \frac{\pi^2 E_y}{12(1 - \nu_{xy} \nu_{yx})} \left(\frac{t}{b}\right)^2 \left[ m^2 \frac{E_x}{E_y} \left(\frac{b}{\ell}\right)^2 + 2 \frac{E_y \nu_{xy} + 2G_{xy}(1 - \nu_{xy} \nu_{yx})}{E_y} + \frac{1}{m^2} \left(\frac{\ell}{b}\right)^2 \right] \times E_x$$

where

$b$  is the panel dimension of the loaded edge (not necessarily the smallest dimension), in mm;

$l$  is the panel dimension of the

unloaded edge, in mm;  $E_x$  is the

flexural modulus along the x axis, in

$N/mm^2$ ;  $E_y$  is the flexural modulus

along the y axis, in  $N/mm^2$ ;

$\nu_{xy}$  is the Poisson's ratio due to stress along the x axis;

$\nu_{yx}$  is the Poisson's ratio due to stress along the y axis;

NOTE 1  $\nu_{yx} = \nu_{xy} (E_y/E_x)$ .

$m$  is the number of half waves in length  $a$  and takes the integer value which minimizes the formula in Equation (D.6).

NOTE 2: The integer values are those either side of the real number  $(alb)(E_y/E_x)^{1/4}$ .

It is therefore considered that all the equations needed for the assessment of the critical buckling stress for FRP single skin are beyond the scope of this annex. In order to assess it, the methods developed in documents such as Reference [24], or equivalent, shall be used.

#### **D.4.4 Buckling of an orthotropic FRP sandwich panel**

An approximate value for the buckling stress for sandwich panels may be obtained using an adaptation of Equation (D.6) where flexural rigidity terms are used in place of  $E_x t^3/12$ , etc. This is acceptable for cores of high shear stiffness (balsa), but it cannot be used for foam and similar cores.

It is therefore considered that all the equations needed for the assessment of the critical buckling stress for FRP sandwich panels are beyond the scope of this Annex.

Euler panel stresses may be obtained by numerical procedures, provided boundary conditions are taken as those of simple support.

## Bibliography

### c) ISO small craft standards

- [1] ISO 12217 (all parts), *Small craft — Stability and buoyancy assessment and categorisation*
- [2] ISO 2553:1992, *Welded, brazed and soldered joints — Symbolic representation on drawings*
- [3] ISO 12215-3, *Small craft — Hull construction and scantlings — Part 3: Materials: Steel, aluminium alloys, wood, other materials*

### d) Welding standards

- [4] ISO 4063:1998, *Welding and allied processes — Nomenclature of processes and reference numbers*
- [5] ISO 5817:2003, *Welding — Fusion-welded joints in steel, nickel, titanium and their alloys (beam welding excluded) — Quality levels for imperfections*
- [6] ISO 6520-1:1998, *Welding and allied processes — Classification of geometric imperfections in metallic materials — Part 1: Fusion welding*
- [7] ISO 6520-2:2001, *Welding and allied processes — Classification of geometric imperfections in metallic materials — Part 2: Welding with pressure*
- [8] ISO 9692-1:2003, *Welding and allied processes — Recommendations for joint preparation — Part 1: Manual metal-arc welding, gas-shielded metal-arc welding, gas welding, TIG welding and beam welding of steels*
- [9] ISO 9692-2:1998, *Welding and allied processes — Joint preparation — Part 2: Submerged arc welding of steels*
- [10] ISO 9692-3:2000, *Welding and allied processes — Recommendations for joint preparation — Part 3: Metal inert gas welding and tungsten inert gas welding of aluminium and its alloys*
- [11] ISO 9692-4:2003, *Welding and allied processes — Recommendations for joint preparation — Part 4: Clad steels*
- [12] ISO 10042:1992, *Arc-welded joints in aluminium and its weldable alloys — Guidance on quality levels for imperfections*
- [13] ISO 13920:1996, *Welding — General tolerances for welded constructions — Dimensions for lengths and angles — Shape and position*
- [14] ISO 15607:2003, *Specification and qualification of welding procedures for metallic materials — General rules*
- [15] EN 287-1:2004, *Qualification test of welders — Fusion welding — Part 1: Steels*

### e) Other documents

- [16] GREEN and Associates, *Marine Composites*, 2nd edition, 1999, ISBN 0-9673692-0-7

DRAFT STANDARD FOR PUBLIC COMMENTS