

Foreword

This draft Zanzibar standard has been developed by Stationery and Paper Products Standard Technical Committee (TCC8). In accordance with Zanzibar Bureau of Standards (ZBS) general procedures, this draft standard is presented to the public in order to receive any technical comment concerns.

Technical Committee Representatives

This Draft Zanzibar National Standard was prepared by the Stationery and Paper Products Standards Technical Committee which consists of representatives from the following organizations:

Chief Government Chemist Laboratory Agency (CGCLA)
Department of Environment (DoE)
Zanzibar Government Printing Press agency (ZAGPA)
Supplier Yaks
Zanzibar Bureau of Standards (ZBS) – Secretariat

Zanzibar Bureau of Standards (ZBS)
PO Box 1136
Zanzibar
Tel: +255 24 2232225
Fax: +255 24 2232225
E-mail: info@zbs.go.tz
Web: www.zbs.go.tz

DRAFT FOR STAKEHOLDERS COMMENTS

Ball point pen ink — Specification

1 Scope

This document establishes minimum quality requirements for ball point pens (refillable or non-refillable) and refills for general use.

Additional requirements for ball point pens for documentary use are given in ISO 12757-2.

2 Normative references

The following referenced documents are indispensable for the application of this document. For dated references, only the edition cited applies. For undated references, the latest edition of the referenced document (including any amendments) applies.

ISO 105-A02, *Textiles — Tests for colour fastness — Part A02: Grey scale for assessing change in colour*

ISO 105-B02, *Textiles — Tests for colour fastness — Part B02: Colour fastness to artificial light: Xenon arc fading lamp test*

ISO 534, *Paper and board — Determination of thickness, density and specific volume*

ISO 535, *Paper and board — Determination of water absorptiveness — Cobb method*

ISO 536, *Paper and board — Determination of grammage*

ISO 868, *Plastics and ebonite — Determination of indentation hardness by means of a durometer (Shore hardness)*

ISO 2144, *Paper, board and pulps — Determination of residue (ash) on ignition at 900 degrees C*

ISO 8791-4, *Paper and board — Determination of roughness/smoothness (air leak methods) — Part 4: Print-surf method*

3 Terms and definitions

For the purposes of this document, the terms and definitions given in ISO 12756 apply.

ISO and IEC maintain terminological databases for use in standardization at the following addresses:

- IEC Electropedia: available at <http://www.electropedia.org/>
- ISO Online browsing platform: available at <http://www.iso.org/obp>

4 Requirements

4.1 Tip classification

Tips shall be classified according to ball diameter (see Table 1).

Table 1

Tip classification (line width)	Tip code	Dimensions in millimetres
		Ball diameter
Extra fine	EF	$\varnothing < 0,65$
Fine	F	$0,65 \leq \varnothing < 0,85$
Medium	M	$0,85 \leq \varnothing < 1,05$
Broad	B	$1,05 \leq \varnothing$

4.2 Shapes and dimensions of refills

Refills shall be classified into types A, B, D, E, F, G and H. The shapes and dimensions of types A to G are given in Figures 1 to 4 and Tables 2 and 3. Refills with shapes and dimensions other than those specified in Tables 2 and 3 and Figures 1 to 4 are designated type H.

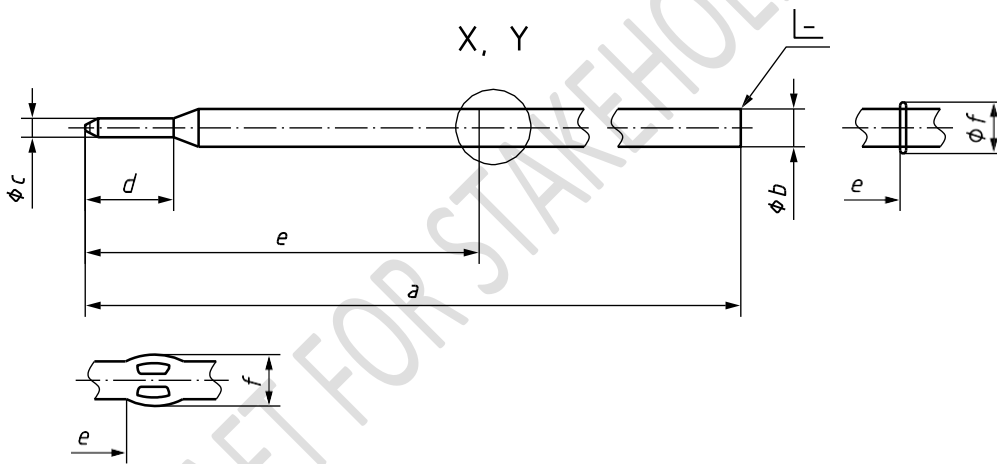

Figure 1

PCD 825: 2026

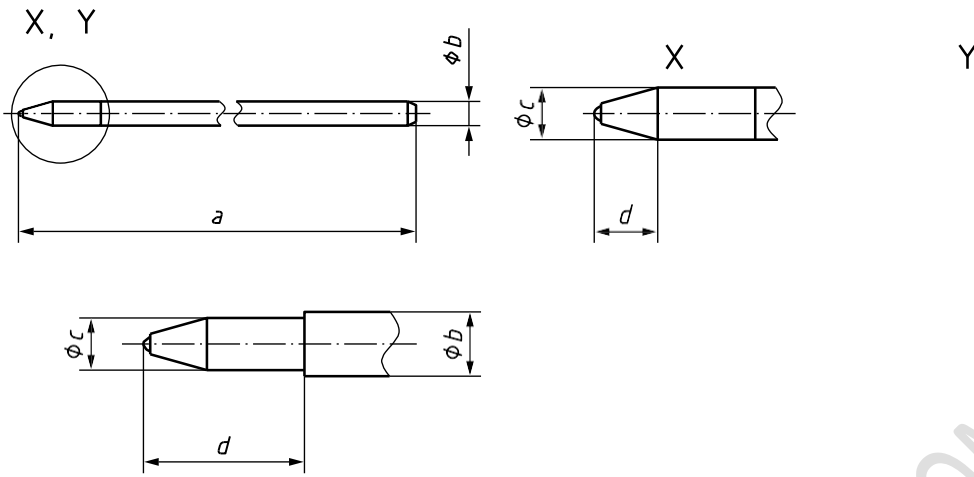

Figure 2

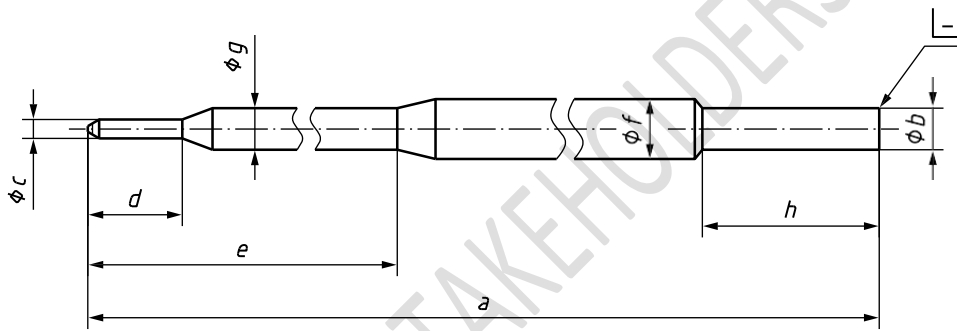

Figure 3

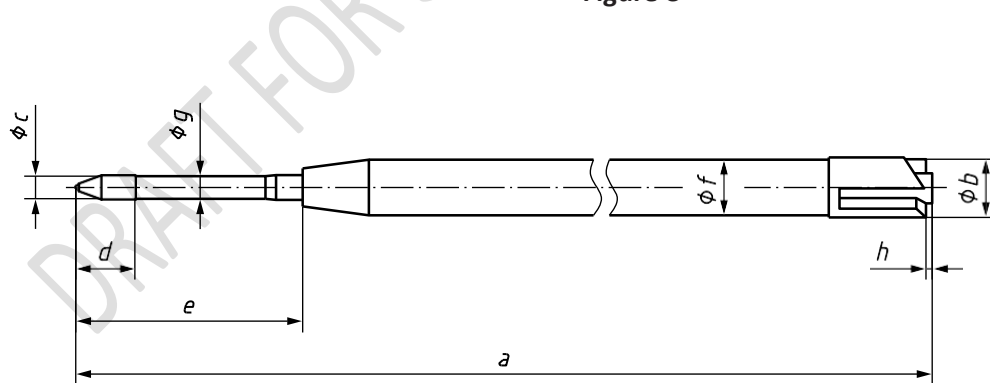

Figure 4

Table 2

Dimensions in millimetres

Type code	Figure	<i>a</i>	<i>b</i>	<i>c</i>	<i>d</i>	<i>e</i>	<i>f</i>
A1	1	106,8 ±0,2	3,2 ⁰ _{-0,2}	2,4 ±0,02	10,2 ±0,5	33,4 ^{+0,5} ₀	4,3 ±0,2
A2	1	106,8 ±0,2	3,2 ⁰ _{-0,2}	1,6 ±0,02	7,5 ^{+0,5} ₀	33,4 ^{+0,5} ₀	4,3 ±0,2
B	1	98,2 ±0,8	3 ^{+0,2} _{-0,1}	2,28 ±0,04	≥7	23 ±2	4,5 ±0,2
D	2X	67 ^{+0,3} ₀	2,35 ⁰ _{-0,05}	2,35 ^{+0,05} ₀	3 ±0,2	—	—
E	2Y	140 ±2	3 ^{+0,2} _{-0,1}	2,25 ±0,03	7,5 ±0,05	—	—
F	2Y	143 ±2	3 ^{+0,2} _{-0,1}	2,3 ±0,03	8,5 ±0,5	—	—

Table 3

Dimensions
in millimetres

Type code	Figure	<i>a</i>	<i>b</i>	<i>c</i>	<i>d</i>	<i>e</i>	<i>f</i>	<i>g</i>	<i>h</i>
G1	3	106,8 ±0,2	3,2 ⁰ _{-0,05}	1,6 ±0,02	7,5 ^{+0,5} ₀	30,5 ±0,25	5 ±0,05	3,3 ⁰ _{-0,1}	13,8 ±0,5
G2	4	98,1 ^{+0,40} _{-0,35}	6 ^{+0,1} _{-0,2}	2,54 ^{+0,03} _{-0,04}	6,2 ±0,2	23,2 ±1	5,8 ±0,1	2,4 ±0,1	0,6 ±0,2

4.3 Performance

4.3.1 Writing performance

Smooth writing shall start within 20 cm and the writing distance shall be at least 300 m without obvious starving or fluctuation of line intensity when tested as specified in [6.3.1](#).

4.3.2 Strike through

No strike through shall be evident to a trained eye when tested as specified in [6.3.2](#)

4.3.3 Drying time

PCD 825: 2026

The line shall be found non-smearing when tested as specified in [6.3.3](#).

4.3.4 Reproducibility

The reproduced line shall be visible when tested as specified in [6.3.4](#).

4.3.5 Water resistance

The line shall remain visible when tested as specified in [6.3.5](#).

4.3.6 Light resistance

The line shall remain visible when tested as specified in [6.3.6](#).

4.3.7 Shelf life

The ball point pen or refill shall conform with [4.3.1](#) when tested as specified in [6.3.7](#).

5 Test equipment and accessories

5.1 Write test machine

The write test machine (see ISO 12756) shall be set to each of the following conditions when performing the machine writing test:

- a) point load: $1,5 \text{ N} \pm 0,1 \text{ N}$;
- b) writing angle: test write a sample at $75^\circ \pm 5^\circ$, determine at which angle the trace is most consistent and select this angle;
- c) writing speed: $4,5 \text{ m/min} \pm 0,5 \text{ m/min}$; and
- d) writing pattern: continuous spiral line (100 mm circumference) with a pitch between 1 mm and 5 mm.

5.2 Performance testing paper specifications

The performance testing paper shall conform to the specifications given in Table 4.

Table 4

Specification		Reference International Standard
Grammage:	$80 \text{ g/m}^2 \pm 5 \text{ g/m}^2$	ISO 536
Smoothness: ^a	$3 \mu\text{m} \pm 0,25 \mu\text{m}$	ISO 8791-4
Residue after incineration:	$(11 \pm 1) \% \text{ residue (ash) at } 900^\circ\text{C}$	ISO 2144
Cobb value:	$18 \text{ g/m}^2 \pm 2 \text{ g/m}^2 (45'') (\triangle \text{Cobb}_{60} = 20 \text{ g/m}^2 \pm 3 \text{ g/m}^2)$	ISO 535
Thickness:	$80 \mu\text{m} \pm 5 \mu\text{m}$	ISO 534
Colour:	white	—
Composition:	100 % wood cellulose fibre, bleached	—

^a Soft backing side used for testing, clamping pressure 1 MPa.

5.3 Eraser

Eraser without abrasive and with a hardness of (45 ± 5) Shore A, in accordance with ISO 868.

5.4 Reproducibility apparatus

Photocopier, microfilm processor or telefacsimile machine.

5.5 Light test apparatus

Fade-o-meter, xenotest or technical equivalent.

6 Testing

6.1 Sampling

Ball point pen and refill samples shall be tested within 6 months after manufacture, except for the shelf life test (see [6.3.7](#)).

6.2 Climatic conditions for testing

The test shall be carried out under standard test atmosphere of either 23/50 (23 °C, 50 % relative humidity) or 27/65 (27 °C, 65 % relative humidity) and according to conditions at the place of testing. Ordinary tolerances (temperature ± 2 °C, relative humidity $\pm 5\%$) are to be applied.

NOTE: The resultant limits of relative humidity are therefore: (45 % to 55 %) and (60 % to 70 %).

6.3 Procedure

6.3.1 Writing performance test

Take a quantity of at least 10 ball point pens and/or refills at random. Generate a continuous 5 m line on the testing paper specified in [5.2](#) by the write test machine specified in [5.1](#) under the climatic conditions specified in [6.2](#). Lift the pens off the paper and allow to rest for 3 h.

Generate 300 m of writing and examine for compliance with [4.3.1](#). Use this machine-written test sheet for the following tests, except for [6.3.3](#) (drying time test) and [6.3.7](#) (shelf life test).

6.3.2 Strike through test

Prepare a machine-written test piece approximately 5 cm long, without the beginning and end of a written line, from the test sheet provided in [6.3.1](#) and keep it under the climatic conditions specified in [6.2](#) for 24 h.

Examine the back of the test paper for compliance with [4.3.2](#).

6.3.3 Drying time test

Draw a straight line in accordance with [5.1](#) a), b) and c) on the testing paper specified in [5.2](#). After 20 s, rub once perpendicularly across the written line with the eraser specified in [5.3](#).

Examine the line for compliance with [4.3.3](#).

PCD 825: 2026

6.3.4 Reproducibility test

Reproduce the written line from a machine-written test piece approximately 5 cm long from the test sheet provided in 6.3.1 using the apparatus specified in 5.4

Examine the reproduced line for compliance with [4.3.4](#).

6.3.5 Water resistance test

Keep a machine-written test piece approximately 5 cm long from the test sheet provided in [6.3.1](#) under the climatic conditions specified in [6.2](#) for 2 h, then immerse in distilled water or de-ionized water for 1 h. Remove and allow to air dry.

Examine the written line of the test piece for compliance with [4.3.5](#).

6.3.6 Light resistance test

Expose a machine-written test piece approximately 5 cm long from the test sheet provided in [6.3.1](#) to the light source of the apparatus specified in [5.5](#), together with the blue wool references specified in ISO 105-B02, until the contrast between the unexposed and the exposed blue wool reference 3 becomes equal to grey scale grade 4 specified in ISO 105-A02.

Examine the written line of the test piece for compliance with [4.3.6](#).

6.3.7 Shelf life test

Select a quantity of at least 10 recently manufactured and unused ball point pens and/or refills. Store horizontally at a temperature of $(40 \pm 2) ^\circ\text{C}$ and at a relative humidity of $(55 \pm 5) \%$ for 90 days.

Test in accordance with [6.3.1](#) and examine for compliance with [4.3.7](#).

7 Designation and marking

7.1 Designation

The designation of a ball point pen or refill shall comprise, in the given order, the following elements:

- a) the description block (e.g. "ball point pen" or "ball point refill");
- b) the number of this document, i.e. ISO 12757-1;
- c) the type classification code for refills (see [4.2](#)); and
- d) the tip classification code (EF, F, M or B; see [Table 1](#)).

EXAMPLES

A disposable ball point pen complying with the requirements of this document with a medium-sized tip (M), shall be designated as follows:

Ball point pen ISO 12757-1 M

A ball point refill complying with the requirements of this document, type B, with a broad sized tip

PCD 825: 2026

(B), shall be designated as follows:

Ball point refill ISO 12757-1 B B

7.2 Marking

For identification, disposable ball point pens or refills shall be marked as follows:

- a) the name of the manufacturer, supplier or trademark;
- b) the designation in accordance with 7.1 [except 7.1 a), which is optional]; and
- c) the date of manufacture (year/month, in full or coded) or the batch number.

8 Test report

The test report shall include the following information:

- a) a reference to this document, i.e. ISO 12757-1;
- b) the date and place of test;
- c) precise identification of the samples (see [7.2](#));
- d) identification of the following variable or optional requirements:
 - test atmosphere (see [6.2](#)),
 - writing angle and writing pitch (see [5.1](#)),
 - reproducibility apparatus (see [5.4](#)), and
 - light test apparatus (see [5.5](#));
- e) the results in accordance with this document;
- f) any deviations from the specified procedures (see [Clauses 5](#) and [6](#)); and
- g) the identification and signature of the tester.