



PCD 823: 2026
ICS 11.040.20

DRAFT ZANZIBAR NATIONAL STANDARD

Rubber bands — General requirements and test methods

DRAFT FOR STAKEHOLDERS COMMENT

ZANZIBAR BUREAU OF STANDARDS

©ZBS 2026- All rights reserved

First Edition

PCD 823: 2026

Foreword

This draft Zanzibar standard has been developed by Packaging and Polymer Standard Technical Committee (TCC8). In accordance with Zanzibar Bureau of Standards (ZBS) general procedures, this draft standard is presented to the public in order to receive any technical comment concerns.

Technical Committee Representatives

This Draft Zanzibar National Standard was prepared by the Packaging and Polymer Standards Technical Committee which consists of representatives from the following organizations:

Chief Government Chemist Laboratory Agency (CGCLA)
Karume Institute of Science and Technology (KIST)
University of Dar es salaam - COeT
Zanzibar Environmental Management Authority (ZEMA)
Zainab Bottlers
Zanzibar Bureau of Standards (ZBS) – Secretariat

Zanzibar Bureau of Standards (ZBS)
PO Box 1136
Zanzibar
Tel: +255 24 2232225
Fax: +255 24 2232225
E-mail: info@zbs.go.tz
Web: www.zbs.go.tz

DRAFT FOR STAKEHOLDERS COMMENT

PCD 823: 2026

Rubber bands — General requirements and test methods

1 Scope

This draft Zanzibar National Standard specifies general requirements and relevant test methods for rubber bands made of dry natural rubber used for general purposes such as for daily wrapping or packaging.

This standard is not applicable for cover rubber bands made of blend and synthetic rubbers. This standard is not applicable for rubber bands used for engineering applications, for food contact, nor for medical uses.

2 Normative references

The following documents are referred to in the text in such a way that some or all of their content constitutes requirements of this document. For dated references, only the edition cited applies. For undated references, the latest edition of the referenced document (including any amendments) applies.

ISO 37, *Rubber, vulcanized or thermoplastic — Determination of tensile stress-strain properties*

ISO 188, *Rubber, vulcanized or thermoplastic — Accelerated ageing and heat resistance tests*

ISO 2781, *Rubber, vulcanized or thermoplastic — Determination of density*

ISO 23529, *Rubber — General procedures for preparing and conditioning test pieces for physical test methods*

3 Terms and definitions

For the purpose of this document, the following terms and definitions shall apply.

ISO and IEC maintain terminological databases for use in standardization at the following addresses:

- IEC Electropedia: available at <http://www.electropedia.org/>
- ISO Online browsing platform: available at <http://www.iso.org/obp>

PCD 823: 2026

3.1

rubber band

elastic circular band used for holding things together

3.2

lay flat length

half of the inner circumference of the rubber band

3.3

cut-width

distance between the two cut surfaces of the rubber band

3.4

thickness

half the difference between the inside diameter and outside diameter of the rubber band

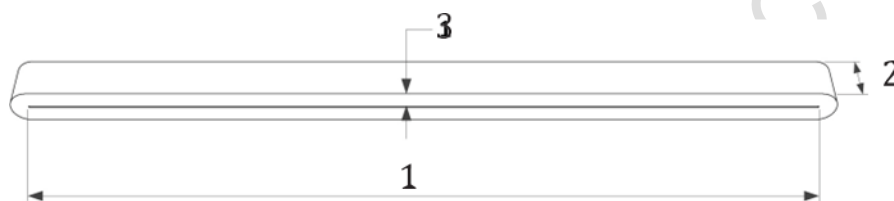

Key

- 1 lay flat length
- 2 cut-width
- 3 thickness

Figure 1 — Lay flat length, cut-width and thickness of a rubber band

4 Classification

Rubber bands are classified into three types:

- Type 1, bands with low modulus;
- Type 2, bands with moderate to high modulus;
- Type 3, bands without modulus requirement.

5 Requirements

5.1 General

Rubber bands shall have a uniform finish and free from discoloration, thin spots, air bubbles, embedded particles, tackiness, and other blemishes likely to affect its serviceability (through a visual inspection).

5.2 Dimensions

The dimensions (lay flat length, cut-width and thickness) of rubber bands shall be, unless agreed between the manufacturer and the buyer otherwise, designated as marking. The tolerances on dimensions are given in [Table 1](#).

Table 1 — Tolerances for dimensions of rubber bands

Dimensions	Tolerance
Lay flat length	
— less than 25 mm	±8,0 %
— between 25 mm and 100 mm	±5,0 %
— above 100 mm	±3,2 %
Thickness	
— less than 1 mm	±0,2 mm
— between 1 mm and 1,6 mm	±0,3 mm
— above 1,6 mm	±15 %
Cut-width	
— less than 3 mm	±10 %
— between 3 mm and 12 mm	±9 %
— above 12 mm	±7 %

5.3 Physical properties

Physical properties of rubber bands shall comply with the requirements given in [Table 2](#).

Table 2 — Required physical properties

Physical properties	Requirements			Test method
	Type 1	Type 2	Type 3	
Modulus at 300 % elongation, MPa	≤2,0	>2,0	Not required	6.3
Tensile strength, MPa, min.				
— tube sample	17,0	15,5	10,0	6.3.1
— ring sample	17,0	15,5	10,0	6.3.2
Elongation at break, %, min.				
— tube sample	700	650	500	6.3.1
— ring sample	600	550	450	6.3.2
Tension set, %, max.	7	10	13	6.4
Density, g/cm ³ , max.	1,0	1,1	1,3	6.5
After accelerated-ageing test				6.6
Change in tensile strength, %, max.	20	20	20	6.4
Change in elongation at break, %, max.	20	20	20	6.4

6 Test methods

6.1 General

All measurements shall be made at standard laboratory temperature after conditioning in accordance with ISO 23529 for at least 3 h.

6.2 Dimensions

Only perform the dimension measurement on the finish rubber band products, not on the uncut rubber tube.

6.2.1 For each dimension, a minimum of three pieces of rubber bands shall be measured and the average value shall be reported.

PCD 823: 2026

6.2.2 For lay flat length, cut a rubber band test piece to open its loop and place a strip on flat surface. The measurement shall be made on the inner side of the strip to the nearest 0,1 mm using appropriated measuring devices e.g. vernier caliper, calibrated tape and ruler. The lay flat length shall be reported as half the measured length of the strip.

Alternatively, an assisting tool may be employed to measure the lay flat length providing that its accuracy is appropriate. The example of the assisting tool is shown in [Figure 2](#).

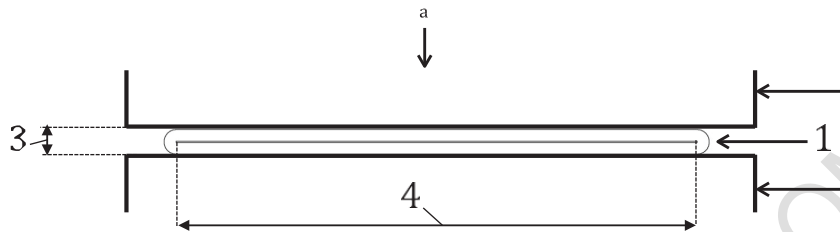

Key

- | | | | |
|---|---------------------|---|---------------------|
| 1 | rubber band | 3 | twice the thickness |
| 2 | assisting tool | 4 | lay flat length |
| a | Pressing direction. | | |

Figure 2 — Assisting tool for the measurement of lay flat length

6.2.3 For cut-width, the measurements shall be made at four approximately equally spaced positions around the ring. Measure the cut-width to the nearest of 0,1 mm using suitable measuring devices e.g. vernier caliper, calibrated tape and magnifying microscope. The average value of each set of measurements shall be recorded.

6.2.4 For thickness, the measurements shall be made at four approximately equally spaced positions around the ring. Measure the thickness to the nearest of 0,01 mm using a thickness gauge. The average value of each set of measurements shall be recorded.

In some cases, the rubber bands can be cut or stacked before measuring the thickness. Other suitable measuring devices, e.g. magnifying microscope and force gauge, can be employed providing that their accuracy are appropriate.

6.3 Tensile properties

Where test pieces are required, they may be taken from an uncut tube shape sample (tube sample) or a finish product (ring sample). The tube sample is cut to dumb-bell-shaped type 1A or type 2 whilst the ring sample is used as it is.

Dumb-bell and ring test pieces do not necessarily give the same values for their respective tensile properties. The results obtained for a sample are likely to vary according to the type of test pieces used as well as the different formulations. Therefore, in case of dispute, the dumb-bell test piece shall be used for the referee test.

6.3.1 Test method A: Tube sample

Tensile properties shall be measured in accordance with ISO 37 using dumb-bell type 1A or type 2 test pieces. A dumb-bell test piece shall be cut across the direction of extrusion of uncut tubes (see [Figure 3](#)). A minimum of three test specimens shall be taken and the median value shall be reported. In case of dispute, dumb-bell type 2 is the preferred test method.

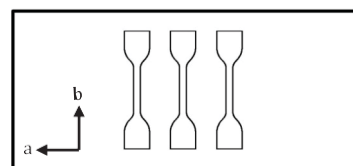
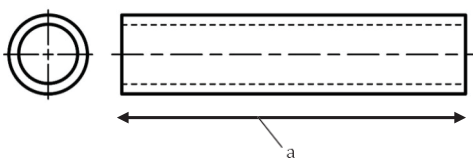

a) Uncut tube rubber band sample

b) Dumb-bell cutting direction

Key

- a Direction of extrusion.
- b Dumb-bell cutting direction.

Figure 3 — An uncut tube sample and cutting direction for dumb-bell test pieces

In case of a small tube sample, dumb-bell cutting across the direction of extrusion cannot be conducted, test method B shall be performed.

6.3.2 Test method B: Ring sample

6.3.2.1 An example of a rig for tensile property tests on ring samples is shown in [Figure 4](#). An upper and a lower roller grips shall have a flat surface with diameter (C_p) suitable to the ring sample sizes. The upper roller grip shall be free to turn with very low friction and the lower roller grip shall be driven to rotate the ring with speed between 10 rpm and 15 rpm.

6.3.2.2 Measure the cut-width and the thickness of test pieces as described in [6.2.3](#) and [6.2.4](#), respectively. The minimum value of each set of measurements shall be used for calculation.

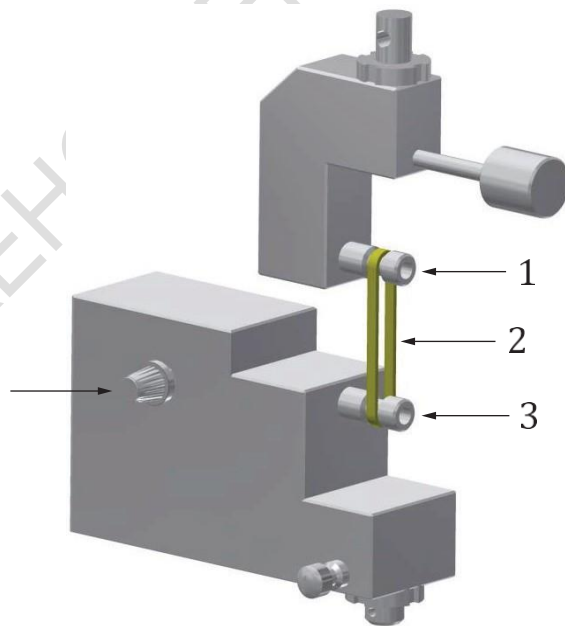

Key

- 1 upper roller grip
- 2 rubber band
- 3 lower roller grip
- 4 rolling speed adjusting knob

Figure 4 — Example of rig for tensile property test on ring samples

DRAFT FOR STAKEHOLDERS COMMENT

6.3.2.3 Adjust the initial distance between the upper and the lower roller grips. The distance between the two rollers should be enough to hold the samples with a minimum stress. Set the load to zero before mounting the test piece on the pulleys then place the test piece on the pulleys and start the machine with the nominal rate of (500 ± 50) mm/min.

Monitor continuously the distance between the pulleys and the increase in force throughout the test.

6.3.2.4 Calculation of results

Calculate the modulus at 300 % elongation, M_{300} , expressed in MPa, using the formula:

$$M_{300} = \frac{F_{300}}{2 \times t \times w}$$

Where

F_{300} is the force recorded at 300 % elongation, in N;

t is the thickness of the test piece, in mm;

w is the cut-width of the test piece, in mm.

Calculate the tensile strength, S_t , expressed in MPa, using the formula:

$$S_t = \frac{F_{\text{break}}}{2 \times t \times w}$$

where F_{break} is the force recorded at break, in N.

Calculate the elongation at break, E , expressed in %, using the formula:

$$E = \frac{100 \times [(2D + C_p) - C_{is,c}]}{C_{is,c}}$$

where

D is the distance between centres of pulleys at break, in mm;

C_p is the circumference of a pulley, in mm;

$C_{is,c}$ is the circumference of inner side of a ring specimen (twice of lay flat length), in mm.

6.4 Tension set

For a tube sample, the tension set shall be measured using dumb-bell type 1A or type 2 test pieces. A dumb-bell test piece shall be cut across the direction of extrusion of uncut tubes ([Figure 2](#)). For a ring sample, cut a rubber band to open its loop and use as the test piece.

A minimum of three test pieces shall be taken and the median value shall be reported. In case of dispute, dumb-bell type 2 shall be used for the referee test.

Mark a reference length (L_0) of 20 mm on the narrow portion of the dumb-bell test piece or at approximately centre of the rubber strip of the ring test piece. Extend the test piece to 300 % elongation at a constant speed and hold at this strain for 10 min. After release the strain, lay the test piece on a flat non-sticky surface for another 10 min. Tension set, $S_{t,10\text{ min}}$, expressed in %, is calculated by using the formula:

$$S_{t,10\text{ min}} = \frac{100 \times \Delta L}{L_0}$$

where

ΔL is the increasing length, in mm;

L_0 is the reference length, in mm;

1.1 Density

The density of the sample shall be measured in accordance with ISO 2781. A minimum of three test pieces shall be taken and the average value shall be reported.

1.2 Accelerated-ageing test

The accelerated-ageing test of the sample shall be performed in accordance with ISO 188 method A using a cabinet or a cell-type oven at (70 ± 2) °C for (168 ± 2) h.

The tensile strength and elongation at break shall be measured in procedure described in [6.3](#). Change in tensile properties, expressed in %, is calculated by using the formula:

$$\frac{X_a - X_0}{X_0} \times 100$$

where

X_0 is the value of the property before accelerated-ageing;

X_a is the value of the property after accelerated-ageing.

7 Packaging

The material shall be packed to facilitate safe transport and storage.

8 Marking

The packages shall be clearly marked the following items:

- a) product name;
- b) type;
- c) size: lay flat length, cut-width and thickness;
- d) weight or number of pieces;

- e) manufacturer or supplier identification;
- f) date of manufacture and/or manufacturer's identifying lot number; and
- g) country of origin

DRAFT FOR STAKEHOLDERS COMMENT

DRAFT FOR STAKEHOLDERS COMMENT

DRAFT FOR STAKEHOLDERS COMMENT