



**DEAS 1277:2025**

ICS 97.180

## **DRAFT EAST AFRICAN STANDARD**

---

**Geometry set — Specification**

**EAST AFRICAN COMMUNITY**

---



### Copyright notice

This EAC document is copyright-protected by EAC. While the reproduction of this document by participants in the EAC standards development process is permitted without prior permission from EAC, neither this document nor any extract from it may be reproduced, stored or transmitted in any form for any other purpose without prior written permission from EAC.

Requests for permission to reproduce this document for the purpose of selling it should be addressed as shown below or to EAC's member body in the country of the requester:

© East African Community 2025 — All rights reserved  
East African Community  
P.O. Box 1096,  
Arusha  
Tanzania  
Tel: + 255 27 2162100  
Fax: + 255 27 2162190  
E-mail: [eac@eachq.org](mailto:eac@eachq.org)  
Web: [www.eac-quality.net](http://www.eac-quality.net)

Reproduction for sales purposes may be subject to royalty payments or a licensing agreement. Violators may be prosecuted.

**Contents**

Page

<b>Foreword</b> .....	<b>iv</b>
<b>1 Scope</b> .....	<b>1</b>
<b>2 Normative references</b> .....	<b>1</b>
<b>3 Terms and definitions</b> .....	<b>1</b>
<b>4 Instruments</b> .....	<b>1</b>
<b>5 Materials</b> .....	<b>2</b>
<b>6 Manufacture</b> .....	<b>2</b>
<b>7 Dimensions and tolerances</b> .....	<b>7</b>
<b>7.1 Set squares and protractor</b> .....	<b>7</b>
<b>7.2 Measuring scale</b> .....	<b>7</b>
<b>8 Graduations</b> .....	<b>7</b>
<b>9 Marking</b> .....	<b>8</b>
<b>Bibliography</b> .....	<b>9</b>

## Foreword

Development of the East African Standards has been necessitated by the need for harmonizing requirements governing quality of products and services in the East African Community. It is envisaged that through harmonized standardization, trade barriers that are encountered when goods and services are exchanged within the Community will be removed.

The Community has established an East African Standards Committee (EASC) mandated to develop and issue East African Standards (EAS). The Committee is composed of representatives of the National Standards Bodies in Partner States, together with the representatives from the public and private sector organizations in the community.

East African Standards are developed through Technical Committees that are representative of key stakeholders including government, academia, consumer groups, private sector and other interested parties. Draft East African Standards are circulated to stakeholders through the National Standards Bodies in the Partner States. The comments received are discussed and incorporated before finalization of standards, in accordance with the Principles and procedures for development of East African Standards.

East African Standards are subject to review, to keep pace with technological advances. Users of the East African Standards are therefore expected to ensure that they always have the latest versions of the standards they are implementing.

East African Standards are subject to review, to keep pace with technological advances. Users of the East African Standards are therefore expected to ensure that they always have the latest versions of the standards they are implementing.

The committee responsible for this document is Technical Committee EASC/TC 079, *Scholastic Materials*.

Attention is drawn to the possibility that some of the elements of this document may be subject of patent rights. EAC shall not be held responsible for identifying any or all such patent rights.

## Geometry set — Specification

### 1 Scope

This Draft East African Standard specifies the requirements of school type geometry set.

### 2 Normative references

There are no normative references in this document.

### 3 Terms and definitions

No terms and definitions are listed in this document.

ISO and IEC maintain terminological databases for use in standardization at the following addresses:

- ISO Online browsing platform: available at <http://www.iso.org/obp>
- IEC Electropedia: available at <http://www.electropedia.org/>

### 4 Instruments

The geometry sets shall contain at least one of each of the following instruments:

- a) Compass;
- b) Divider;
- c) Protractor, semicircular;
- d) Pair of set squares, 45° and 60°; and
- e) Measuring scale.
- f) Sharpener
- g) Pencil
- h) Eraser

## 5 Materials

5.1 Set squares, measuring scales and protractors in the geometry set shall be made of transparent plastic material, opaque plastic material or tin plate. The recommended plastic materials are polystyrene, acrylic or rigid polyvinyl chloride. The material shall be smooth, even on all sides and free from blisters, porosity and other defects.

5.2 Compasses and dividers shall be made from zinc base die cast alloy or forged brass or rolled brass sheet or brass plated steel sheet. 5.3 The needles in both the grades shall be made from suitable steel and properly heat treated.

5.4 The geometry set shall be made from tin sheet or plastic material with a provision for keeping the instruments separately. The geometry set shall have a flat lid, well fitting, easy to open and without sharp edges. The minimum thickness shall be 0.315 mm for tin sheet and 2 mm for plastic materials.

## 6 Manufacture

6.1 Compasses and dividers shall have a screwed hinge.

6.2 Compasses and dividers shall be made as shown in Figure 1 and Figure 2 respectively.

6.3 The compasses shall be provided with a suitable arrangement for securely holding the pencil. The diameter of the hole for holding the pencil and the thickness of the ring for tightening the pencil shall not be less than 8.2 mm and 2 mm respectively.

6.4 In the case of distance between the two legs in fully closed position shall not exceed 1 mm.

6.5 The set squares, protractor and measuring scale shall be made as shown in Figures 3 to Figure 7. In set squares and the measuring scale, both edges shall carry centimeter graduation marks.

6.6 Set squares may be made with open centre pattern. In the open centre pattern, the minimum distance from the opening to the edge shall not be less than 15 % of nominal size.

6.7 A protractor may be designed with an open-centre pattern and may include a linear measuring scale. .

6.8 The finish of the surface and edges of the set squares, protractor and measuring scale shall be smooth.

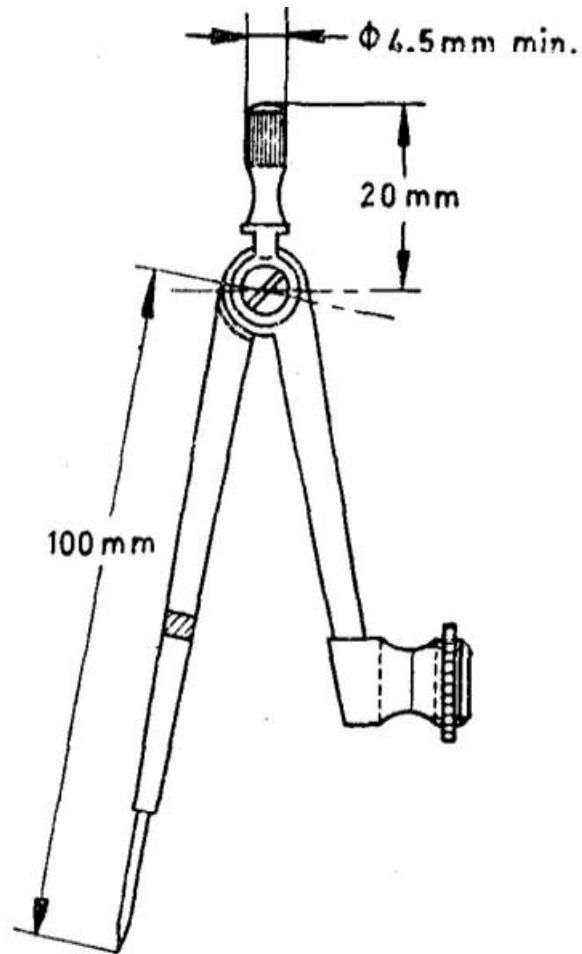

Figure 1 — Compass (Screwed type)



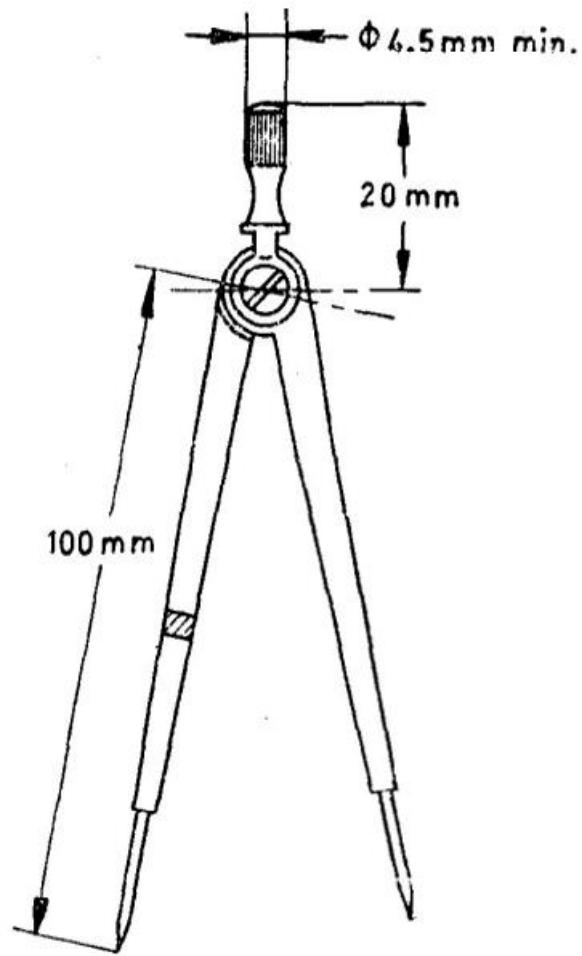

Figure 2 — Divider

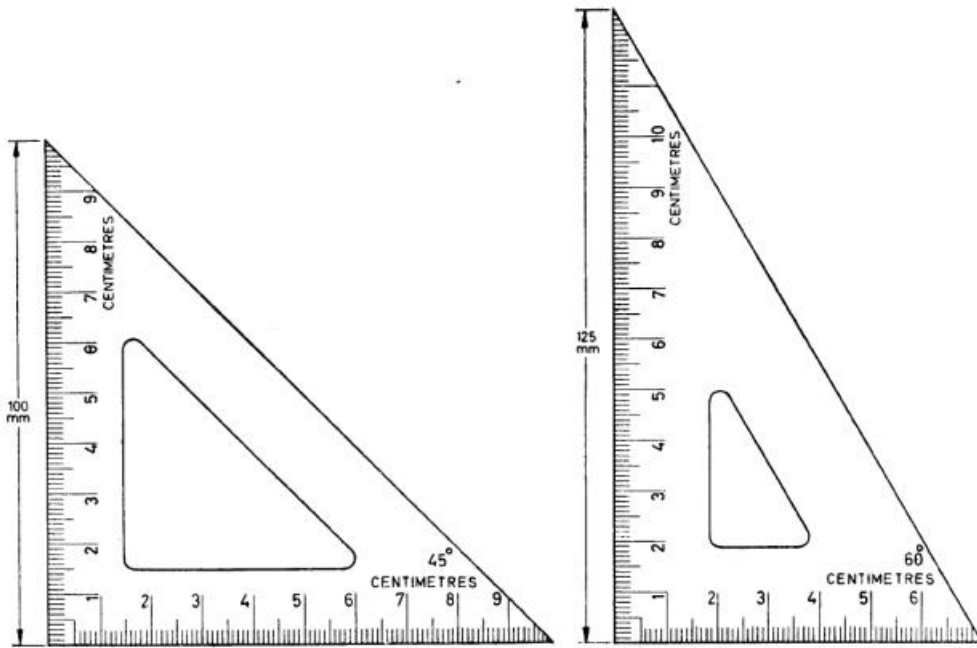

Figure 3 — Set squares, open centre pattern

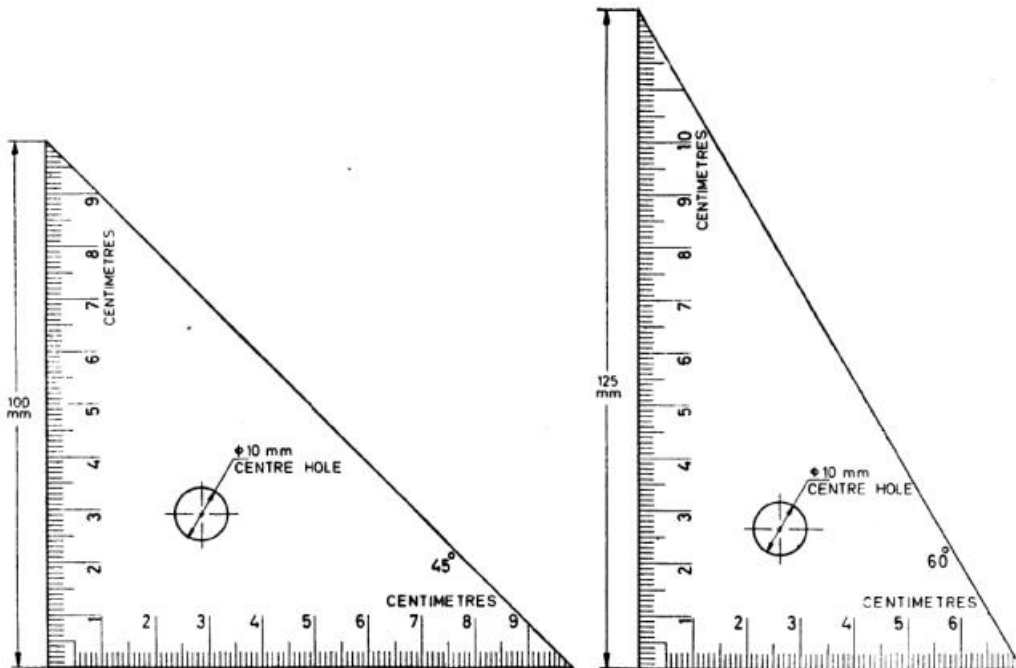

Figure 4 — Set squares, centre hole pattern

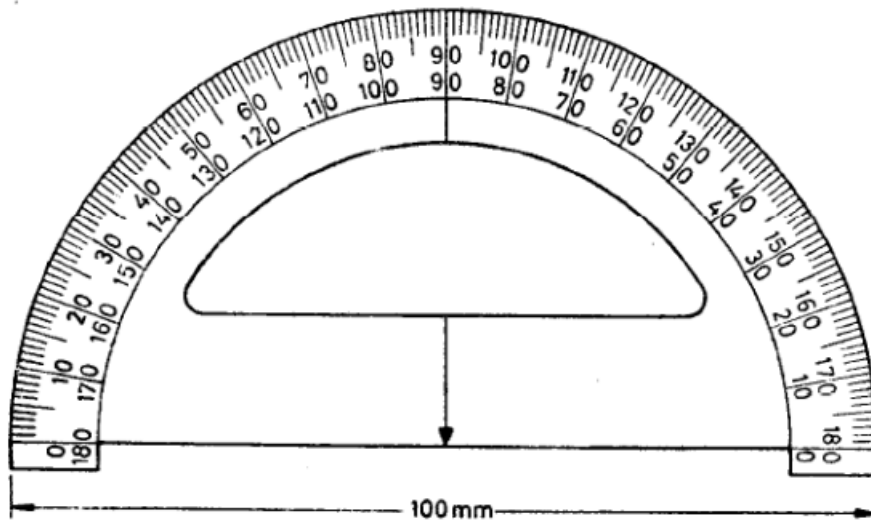

Figure 5 — Protractor, semi-circular, open centre pattern

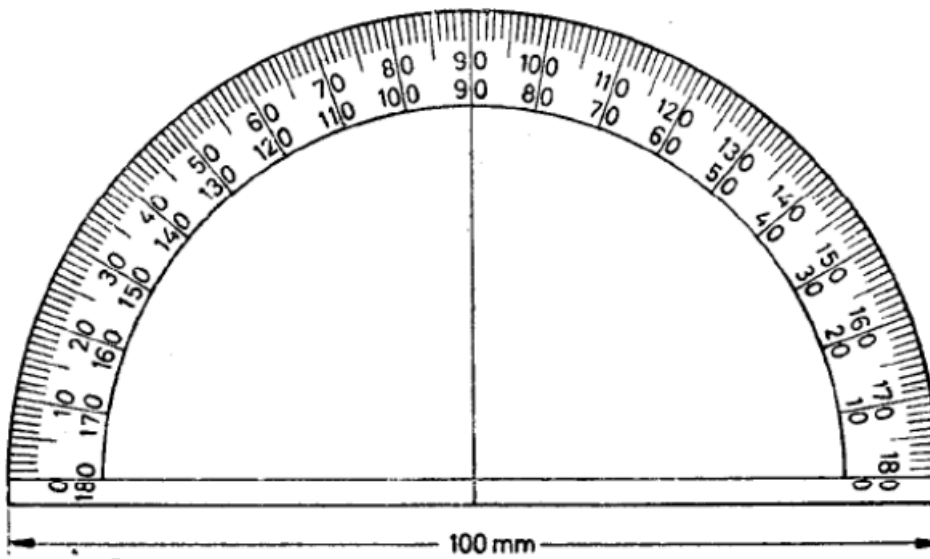

Figure 6 — Protractor, semi-circular, solid pattern

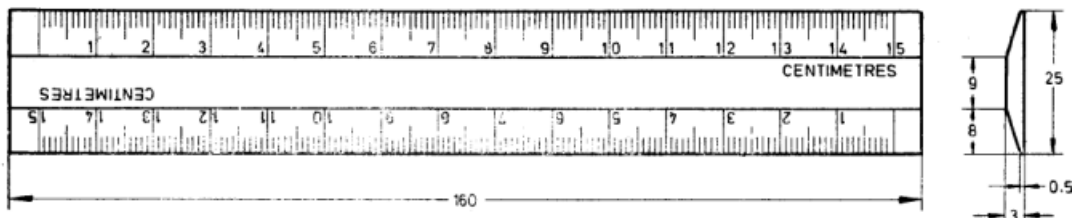

Figure 7 — Measuring scale

## 7 Dimensions and tolerances

### 7.1 Set squares and protractor

The dimensions and tolerances for the set squares and protractor shall be as specified in Table 1 and Table 2 respectively.

**Table 1 — Dimensions and tolerances for set squares**

Designation size	Tolerance on linear dimensions mm	Thickness of plastic material min. mm	Thickness of tinplate min. mm	Angular tolerance arc minutes
45° 100 mm	± 1.5	1.5	0.56	± 15'
60° 125 mm	1.5	1.5	0.56	± 15'

**Table 2 — Dimensions and tolerances for the protractor**

Diameter	Tolerance on diameter mm	Thickness of plastic material min. mm	Thickness of tinplate min. mm	Graduation arc minutes	Angular tolerance arc minutes
Semi-circular 100 mm	± 1.5	1.5	0.56	1'	± 15'

### 7.2 Measuring scale

**7.2.1** The dimensions for the measuring scale shall be 160 x 25 mm.

**7.2.2** The total error for the entire length of the graduated part of the measuring scale shall not exceed ± 0.5 mm.

## 8 Graduations

**8.1** All graduations shall be cut, stamped or engraved on set squares, protractor and measuring scale. The graduations shall be clear, uniform, fine and filled with black colour so as to ensure good legibility without the use of a magnifying glass. The thickness of the graduation lines shall not exceed 0.2 mm.

**8.2** The set squares, protractor and measuring scale shall comply with the recommended lengths for graduations given in Table 3.

**Table 3 — Recommended lengths for graduations for set squares, protractor and measuring scale**

Instrument	Nominal length mm
Set squares:	
• cm graduations	10
• 5-mm graduations	5
• mm graduations	3
Semi-circular protractor:	
• 10-degree graduations	10
• 5-degree graduations	5
• 1-degree graduations	3
Scale:	
• cm graduations	8
• 5-mm graduations	5
• mm graduations	2.5

**8.2.1** The semi-circular protractor shall be double reading and shall be figured at every 10° graduation. The outer figures shall read clockwise from the horizontal line starting from left and those on the inner side shall read anticlockwise starting from the horizontal line starting from right. The height of the figures shall be between 2.25 mm ± 0.25 mm for protractor. The minimum height of the figures in the case of set squares shall be 2.5mm. The circumference of the semi-circular protractor shall be graduated on the underside by radial lines for transparent protractors and on the upper side by radial lines for those made from tinplate or opaque plastic material. Set squares and the measuring scale shall be figured at every centimetre graduation.

**8.2.2** In semi-circular protractor, no graduations shall extend beyond the base line (which is the line joining the graduations 0° and 180°). The base line shall be at least 3 mm away from the bottom straightedge and parallel to it.

**8.2.3** Two straight lines, one in continuation of graduations 0° to 180° and the other perpendicular to it through 90° graduation mark shall be drawn completely to meet at the centre in case of protractor of solid pattern as shown in figure 6. In the case of protractors of open centre pattern, a line shall be drawn joining the graduations 0° and 180°. A perpendicular line, which on extension shall coincide with the graduation mark of 90°, shall be marked to indicate the centre of the circumference.

## 9 Marking

**9.1** The set squares, protractor, measuring scale, compasses and dividers shall be legibly and indelibly marked with maker's name or trade-mark at a suitable place.

**9.2** Each geometry set shall be marked with the maker's name on one of its faces.

**9.3** Geometry sets may also be marked with a certification Mark.

## Bibliography

- [1] IS 2533:1978, *Specification for geometry boxes*
- [2] US 1984:2018, *Geometry sets — Specification*

DRAFT EAST AFRICAN STANDARD FOR PUBLIC REVIEW



DRAFT EAST AFRICAN STANDARD FOR PUBLIC REVIEW